

StepArray+

SA 150P+

DGRC Multi channel Steerable amplified Column Loudspeaker

StepArray+ column loudspeakers ensure perfect speech intelligibility and optimal acoustic comfort, even in noisy and reverberant venues. They are based on the DGRC (Digital & Geometrical Radiation Control) principle patented by Active Audio.

Compared with a classic sound system in which each loudspeaker is controlled independently, the DGRC method makes it possible to decrease the number of channels to be controlled, thereby enhancing economic efficiency.

StepArray+ also allows the use of existing network cables and helps to achieve significant savings in wiring, with up to 64 channels on a single Ethernet cable.

StepArray+ combines the features of Dante™ and StepArray to achieve ever higher levels of efficiency and flexibility.

The StepArray control software can be downloaded for free.

StepArray+ is the first range of Active Audio products incorporating Dante technology.

StepArray+ users appreciate the sound performance and flexibility achieved by the transmission of digital signals.

Dedicated to flat horizontal areas, the SA 150P+ model delivers up to 95dB SPL with a nominal range of 21m.



Max SPL : 97dB at 10m

Bandwidth : 110Hz- 19kHz

Continuous power : 450W

Dante™

Paintable

5 years warranty

For horizontal audience



DGRC principle

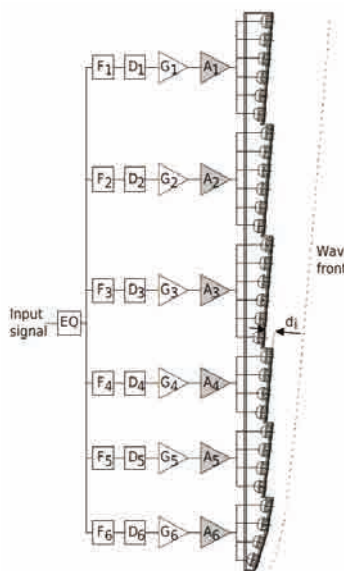

StepArray columns implement the DGRC line-array principle (Digital and Geometric Radiation control) which is a synthesis of geometric and electronic arrays patented by Active audio.

The key idea is to split the desired wave-front into sections and move them back on a vertical line, much like what is done in the Fresnel lenses used in optics. Then electronic delays are used to compensate sound propagation delay between the sections. It was shown in DGRC array that with this delay setting there is no diffraction at the edge of the saw-tooth shape. As a result of this principle, the number of DSP and amplification channels is independent of the number of loudspeakers, so that a dramatically reduced number of channels is achieved.

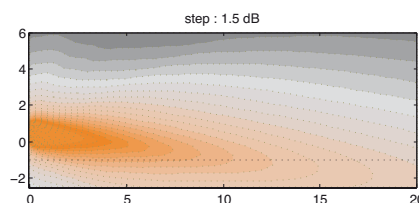

Step Array SA150P+ vertical directivity: sound level for the speech octaves (500Hz-1kHz-2kHz) in the vertical median plane.



SA150P+

Technical Specifications

Mechanical drawing

Front views

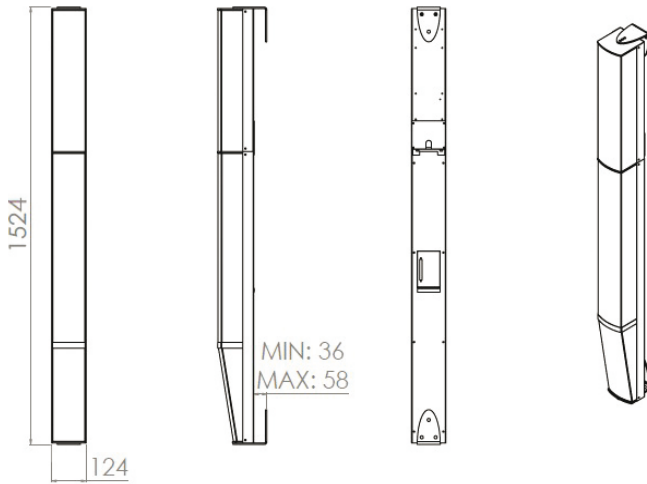

Rigging

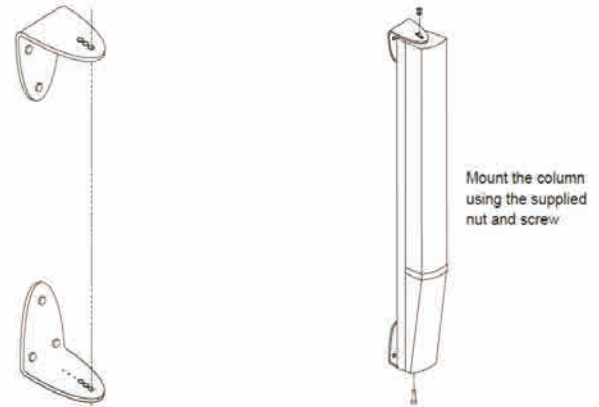

Mount the column using the supplied nut and screw.

Technical Specifications

Acoustical data

Range +/- 3dB	15m
Range +/- 5dB	21m
Max SPL	97dB at 10m
Angle of audience	0°-5°
Frequency bandwidth (-10 dB)	110Hz-19kHz
Horizontal opening angle (1 kHz)	180°
Loudspeaker	12x 3"

Mechanical data

Net weight	14 kg
Shipping weight	17 kg
Height	1524 mm
Width	124 mm
Depth	131 mm
Standard colors	White RAL 9016 Black RAL 9005

Sound level by octave in the axis of the listening plane in front of the column with respect to the distance from the column

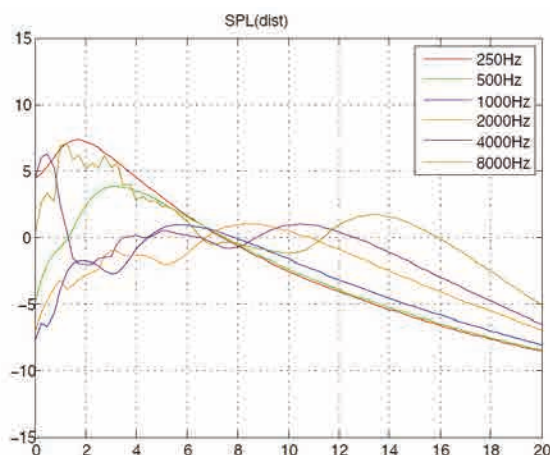

Electrical data

Input	1 x balanced analog euroblock 1 Dante RJ45
Total Amplifier Power	450W Class D
Power supplied	85V to 264V 45Hz-65Hz

Tuning and exploitation

Modeling	EASE and CATT Active Audio prediction software www.activeaudio.fr
Environment	IP 23 Indoor 60°C max
Nominal mounting height	2,5 m

Frequency response

StepArray frequency response. Average from 3 to 12m on axis.
In red: with bass high-pass on position «100Hz»,
In blue: with bass high-pass on position «200Hz»

