

LA4X Amplified Controller

user manual



version 8.0



LA4X Amplified Controller user manual

version 8.0

IMPORTANT SAFETY INSTRUCTIONS



Explanation of Graphical Symbols



The lightning flash with arrowhead symbol within an equilateral triangle is intended to alert the user to the presence of uninsulated “dangerous voltage” within the product’s enclosure that may be of sufficient magnitude to constitute a risk of electric shock to persons.



The exclamation point within an equilateral triangle is intended to alert the user to the presence of important operating and maintenance instructions in the literature accompanying the product.

1. Read these instructions.
2. Keep these instructions.
3. Heed all warnings.
4. Follow all instructions.
5. Do not use this apparatus near water.
6. Clean only with dry cloth.
7. Do not block any ventilation openings. Install in accordance with the manufacturer’s instructions.
8. Do not install near any heat sources such as radiators, heat registers, stoves, or other apparatus (including amplifiers) that produce heat.
9. Do not defeat the safety purpose of the grounding-type plug. A grounding-type plug has two blades and a third grounding prong. The third prong is provided for your safety. If the provided plug does not fit into your outlet, consult an electrician for replacement of the obsolete outlet.
10. Protect the power cord from being walked on or pinched particularly at plugs, convenience receptacles, and the point where they exit from the apparatus.
11. Only use attachments/accessories specified by the manufacturer.
12. Use only with the cart, stand, tripod, bracket, or table specified by the manufacturer, or sold with the apparatus. When a cart is used, use caution when moving the cart/apparatus combination to avoid injury from tip-over. 
13. Unplug this apparatus during lightning storms or when unused for long periods of time.
14. Refer all servicing to qualified service personnel. Servicing is required when the apparatus has been damaged in any way, such as power-supply cord or plug is damaged, liquid has been spilled or objects have fallen into the apparatus, the apparatus has been exposed to rain or moisture, does not operate normally, or has been dropped.
15. **WARNING:** To reduce the risk of fire or electric shock, this apparatus should not be exposed to rain or moisture and objects filled with liquids, such as vases, should not be placed on this apparatus.
16. To completely disconnect this equipment from the mains, disconnect the power supply cord plug from the receptacle.
Pour déconnecter complètement l’appareil du secteur, débranchez la prise de la fiche secteur.



- 17.** The main plug of the power supply cord shall remain readily accessible.
La prise principale du cordon d'alimentation doit rester totalement accessible.

ADDITIONAL IMPORTANT SAFETY INSTRUCTIONS

- 1. Read this manual.**
- 2. Read all SAFETY INSTRUCTIONS carefully as well as DANGER and OBLIGATION warnings.**
- 3. Never incorporate equipment or accessories not approved by L-Acoustics®.**
- 4. Read all the related PRODUCT INFORMATION documents before exploiting a loudspeaker system.**
The **product information** document is included in the shipping carton of the related system component.
- 5. Strictly follow the installation instructions given in this manual.**
To ensure sufficient ventilation, install the apparatus in an open area so that the front and rear panels are located at a minimum distance of 30 cm from any external object or structure.
- 6. Read the MAINTENANCE MANUAL – LEVEL 1 before performing any maintenance operation on the apparatus or in case of malfunction.**
This manual only contains the maintenance operations authorized for the **End User**. Contact L-Acoustics® for advanced maintenance.
- 7. Inspect the apparatus before use.**
If any sign of defect or damage is detected, immediately withdraw the apparatus from use for maintenance.
- 8. Only use the apparatus in a conformed electro-magnetic environment.**
Conformed environments are specified in EN55103-2 standard as *E1* (residential), *E2* (commercial and light industrial), *E3* (urban outdoors), and *E4* (controlled EMC environment, ex. TV studio).
- 9. Avoid radio interference.**
This apparatus has been tested and complies with the limits indicated in the EMC (Electro Magnetic Compatibility) directive. These limits are designed to provide reasonable protection against harmful interference from electrical equipment, but it cannot be guaranteed that interference will never occur.
- 10. Verify the electrical conformity and compatibility of the mains supply.**
Only connect the apparatus to an AC power outlet rated 100-240 V, 50-60 Hz, with the following current values: 20 A for 100-120 V, 10 A for 200-240 V.
WARNING: An apparatus with CLASS I construction shall be connected to a mains socket outlet with a protective connection to earth.
- 11. Verify the electrical conformity and compatibility of the three-phase circuit.**
Verify that each phase works, in particular the neutral one.
Balance the loads between the three phases.
Never try to reproduce a 230 V circuit connecting an apparatus to two live wires of a 120 V three-phase circuit.
Never try to reproduce a 200 V circuit connecting an apparatus to two live wires of a 100 V three-phase circuit.
- 12. Always interconnect a Class C thermal circuit breaker between the apparatus and the mains supply.**
The circuit breaker current rating depends on the mains voltage rating as follows:
20 A for 100-120 V, 10 A for 200-240 V.

LA4X Amplified Controller

user manual

version 8.0

13. Be aware of over power risks.

The apparatus is very powerful and can be potentially dangerous to both loudspeakers and humans alike. Even reducing the gain it is still possible to reach very high output power if the input signal level is high enough.

14. Do not use the apparatus outside its operating temperature range.

The apparatus operates at a room temperature between 0 °C and +50 °C.
Do not expose the apparatus to direct sun.

15. **WARNING: TERMINALS marked with the lightning flash symbol are HAZARDOUS LIVE.**

The external wiring connected to these TERMINALS requires installation by an INSTRUCTED PERSON or the use of ready-made leads or cords.

Never attempt to touch any exposed speaker wiring while the apparatus is operating: first disconnect the connector from the apparatus.

Mute all output channels before connecting a speaker to the apparatus.

Do not connect a speaker output in parallel or series with any output of another amplifier.

Do not connect the speaker outputs to any other voltage source, such as a battery, power mains, or power supply, regardless of whether the apparatus is turned on or off.



16. Do not place naked flame sources, such as lighted candles, on the apparatus.

17. Use the original packaging or accessories approved by L-Acoustics® (rack, case) to transport the apparatus.

SYMBOLS

The following symbols are used in this document:



DANGER

This symbol indicates a potential risk of harm to an individual or damage to the product.

It can also notify the user about instructions that must be strictly followed to ensure safe installation or operation of the product.



ELECTRICAL HAZARD

This symbol indicates a potential risk of electrical injury.

It can also notify the user about instructions that must be strictly followed to ensure safe installation or operation of the product.



OBLIGATION

This symbol notifies the user about instructions that must be strictly followed to ensure proper installation or operation of the product.



EQUIPMENT

This symbol indicates the equipment, tools, and spare parts required to perform a procedure.



INFORMATION

This symbol notifies the user about complementary information or optional instructions.



WELCOME TO L-ACOUSTICS®

Thank you for choosing the L-Acoustics® **LA4X** amplified controller.

This document contains essential information on using the product properly. Carefully read this document in order to become familiar with the product.

As part of a continuous evolution of techniques and standards, L-Acoustics® reserves the right to change the specifications of its products and the content of its document without prior notice.

Please check the L-Acoustics® web site on a regular basis to download the latest document and software updates: l-acoustics.com.

LA4X Amplified Controller user manual

version 8.0

CONTENTS

1	INTEGRATED SYSTEM APPROACH	9
1.1	Presentation	9
1.2	System configurations	9
1.3	System components	9
1.3.1	Powering and driving systems	9
1.3.2	Loudspeaker enclosures and cables	9
1.3.3	Rigging elements	9
1.3.4	Software	10
2	LA4X AMPLIFIED CONTROLLER	11
2.1	Main features	11
2.1.1	Internal components	11
2.1.2	Front and rear panels	11
2.2	Signal processing and amplification	12
2.2.1	Signal inputs	12
2.2.2	DSP architecture	13
2.2.3	Power supply and amplifier section	14
2.2.4	Speaker outputs	14
2.3	Monitoring and control	14
2.3.1	User interface	14
2.3.2	L-NET remote control network	14
3	INSTALLATION	15
3.1	Mounting	15
3.2	Ventilation	16
3.3	Connecting to AC mains	16
3.3.1	AC mains specifications	16
3.3.2	Three-phase circuit	16
3.3.3	Circuit breaker	16
3.3.4	Electrical generator	16
3.3.5	Power cord	17
3.3.6	Power consumption	17
3.3.7	Example of heat power calculation	18



3.4	Audio and network cabling	18
3.4.1	Connection panels	18
3.4.2	Analog SIGNAL cabling	19
3.4.3	Digital SIGNAL cabling	20
3.4.4	SPEAKER cabling	21
3.4.5	L-NET cabling	23
4	OPERATION	24

4.1	Powering on, powering off, selecting the standby mode	24
4.2	Display	25
4.2.1	Main screen	25
4.2.2	LED meters	26
4.2.3	STATUS and L-NET LED	26
4.2.4	OUT LED	26
4.3	User interface	27
4.3.1	Quick access	27
4.3.2	Main menu	30
4.3.3	Access rights, pin code	32
4.4	LOAD PRESET	33
4.5	STORE PRESET	35
4.6	DELETE PRESET	36
4.7	PRESET PARAMETERS	37
4.8	CLEAR GROUP PARAMS	39
4.9	INPUT SETTINGS	40
4.9.1	INPUT MODE	40
4.9.2	FALLBACK MODE	42
4.9.3	AES/EBU GAIN	43
4.10	MONITORING & INFO	44
4.10.1	SPK HANDLING	44
4.10.2	OUT CH TEMP	44
4.10.3	FIRMWARE	45
4.10.4	PRESET LIBRARY	45
4.10.5	MAC ADDRESS	45
4.10.6	HARDWARE INFO	45
4.10.7	ENCLOSURE CHECK	45

LA4X Amplified Controller user manual

version 8.0

4.11	OPTIONS.....	46
4.11.1	NETWORK ADDRESS	47
4.11.2	DELAY UNIT.....	48
4.11.3	SCREEN CONTRAST.....	48
4.11.4	LED & BACKLIGHT MODE	48
4.11.5	RESET TO FACTORY DEFAULT SETTINGS?	49
APPENDIX A: PROTECTION SYSTEMS		50
APPENDIX B: APPROVALS		52
APPENDIX C: SPECIFICATIONS		53



1 INTEGRATED SYSTEM APPROACH

1.1 Presentation

The **LA4X** is an amplified controller based on a 4-input by 4-output architecture and an exclusive green power module providing maximized efficiency. With LA4X, L-Acoustics® speakers can get all the benefits of self-powered speakers, while keeping the versatility of the separated amplification approach.

1.2 System configurations

The L-Acoustics® systems can be operated in three connectivity modes, as described below:

“A LA CARTE” The pool of four inputs and four amplification channels of the LA4X can be allocated “à la carte” to any passive speaker enclosures with a one-to-one-to-one link (input / processing + amplification / loudspeaker). This approach is cost effective for applications requiring a high count of independent sound sources such as stage monitors, multi-channel systems and multi-feed distributed systems.

“FULL ACTIVE” In high-end installation projects, the LA4X can drive active systems, up to K2, for maximum power headroom and the best possible performances. With one transducer section per output channel and the independent DSP treatment of each output, this approach brings maximum discretization with a one-to-one link (processing + amplification / transducer section).

“CONVENTIONAL” For applications requiring a high count of loudspeaker enclosures with optimized cost of amplification, the LA4X can efficiently operate as a conventional amplified controller driving speakers in parallel from its four amplification channels, with the added benefit of the 4 inputs when using passive loudspeaker enclosures.

1.3 System components

The system approach developed by L-Acoustics® consists in offering a global solution that guarantees the highest and most predictable level of performance at any step of loudspeaker system deployment: modeling, installation and operation. A complete L-Acoustics® system includes enclosures, amplified controllers, cables, rigging system, and software applications. The main components of an L-Acoustics® system that includes the LA4X are the following:

1.3.1 Powering and driving systems

LA4X Amplified controller with DSP library and networking capabilities.

1.3.2 Loudspeaker enclosures and cables

 Refer to the **user manuals** of the loudspeaker systems for detailed instructions about the enclosures and their connection to the LA amplified controllers.

1.3.3 Rigging elements

 Refer to the **rigging manuals** of the loudspeaker systems for detailed instructions about the rigging of the enclosures.

LA4X Amplified Controller user manual

version 8.0

1.3.4 Software

LA Network Manager Remote control and monitoring of amplified controllers.

Soundvision 3D acoustical and mechanical modeling.



Software documentation

Refer to the **LA Network Manager video tutorial** and the **Soundvision help**.

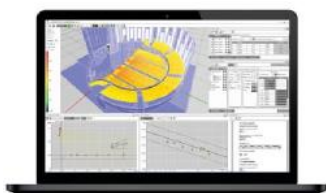

Soundvision



LA Network Manager



LA4X

Figure 1: Main components involved in loudspeaker system design and drive

2 LA4X AMPLIFIED CONTROLLER

2.1 Main features

2.1.1 Internal components

The core of the LA4X is a DSP engine driving four channels of amplification from four inputs. The LA4X also features a flash memory for preset storage and management, high performance A/D-D/A converters for audio signals, a universal SMPS (Switched Mode Power Supply) with PFC (Power Factor Correction), a front panel user interface, and a Fast Ethernet device for network remote control.

2.1.2 Front and rear panels

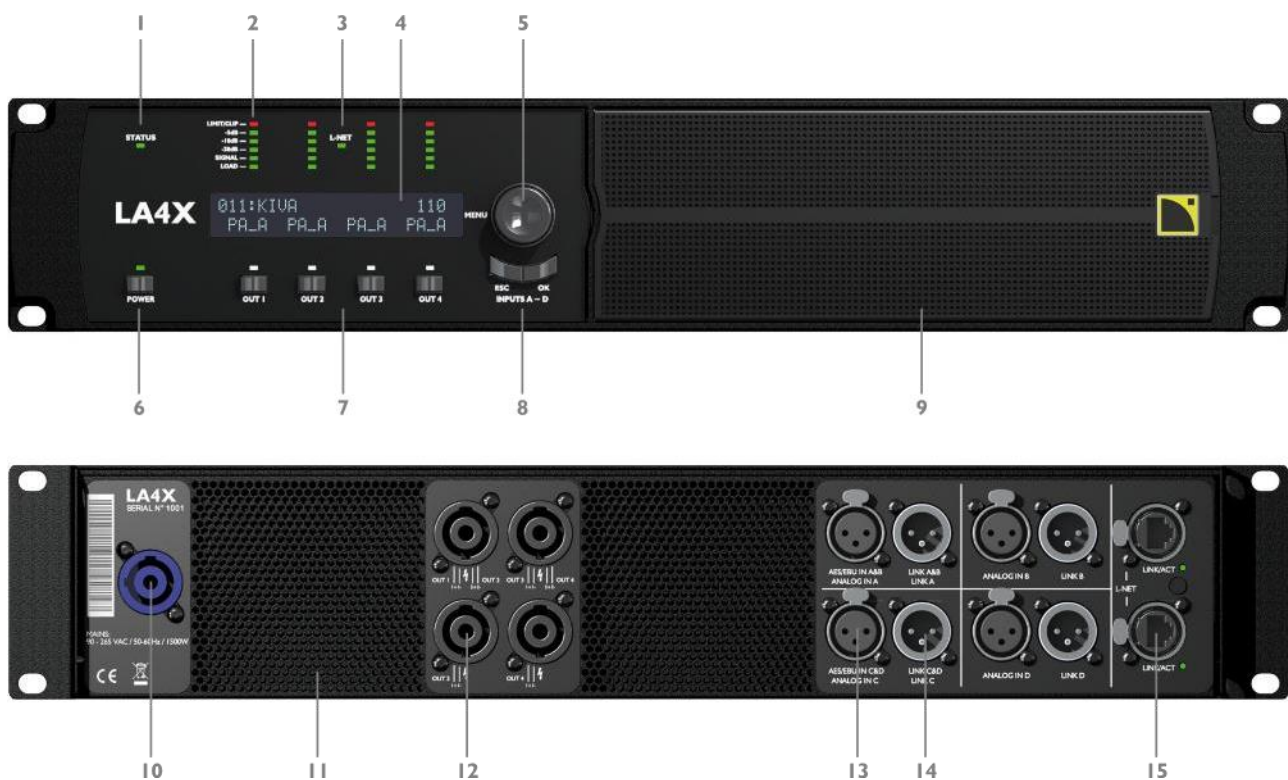

Figure 2: LA4X front and rear panels

- | | |
|---|--|
| <ol style="list-style-type: none"> 1. Status LED 2. LED meters:
LIMIT/CLIP level
audio level (-20, -10, -5 dB)
SIGNAL presence
LOAD presence 3. L-NET network control LED 4. 2x24 characters LCD display 5. navigation/edition encoder wheel 6. power/standby key and LED | <ol style="list-style-type: none"> 7. channel selection keys 8. menu keys 9. inward ventilation grill and foam filter 10. PowerCON power supply connector (20A) 11. outward ventilation grills 12. SpeakON output connectors 13. XLR analog and AES/EBU input connectors 14. XLR analog and AES/EBU link connectors 15. EtherCON L-NET network connectors |
|---|--|

LA4X Amplified Controller

user manual

version 8.0

2.2 Signal processing and amplification

2.2.1 Signal inputs

The LA4X features four input connectors allowing it to receive four analog signals, four digital signals, or two analog and two digital signals, depending on the input mode selected by the user (see section 3.4.1). This architecture also allows digital-to-analog or digital-to-digital fallback.

Analog inputs

The LA4X can be fed with up to four balanced analog audio signals using XLR3 female input connectors ANALOG IN A to ANALOG IN D (see Figure 2). Each analog input port is ESD protected.

The analog input panel also features four XLR3 male link connectors passively wired to the input connectors. They allow transmitting the input signals to daisy-chained amplified controllers. Each analog link port is ESD protected.

To be processed by the DSP, the analog signal must be converted into a digital signal. For this purpose, the LA4X amplified controller is fitted with four cascaded 24-bit A/D converters with a sampling rate of 96 kHz allowing an encoding dynamic range of 128 dB.

AES/EBU digital inputs

The LA4X can be fed with up to four AES/EBU digital audio signals (transported in pairs) using XLR input connectors AES/EBU IN A&B and AES/EBU IN C&D (see Figure 2).

Each AES/EBU input port is an XLR3 female connector. The audio signals can come from a digital mixing desk or a digital audio network bridge compliant with the AES/EBU (AES3) or electrical S/PDIF (IEC 60958 Type II) digital audio standards. Each AES/EBU input port is ESD protected and transformer balanced.

The AES/EBU input panel also features two XLR3 male link ports actively connected to the input ports (with failsafe relay in case of mains absence). They allow transmitting the input signals to daisy-chained amplified controllers. Each AES/EBU link port is ESD protected and transformer balanced.

Each AES/EBU input port is equipped with a Sample Rate Converter (SRC) that has been selected to support a wide range of input formats (16-24 bits/ 44.1-192 kHz). It converts any of them to the 24 bits/96 kHz internal format used by the amplified controller. The SRC is a high-quality hardware component (140 dB dynamic range, THD+N<-120 dBfs, strong input jitter attenuation) and provides constant propagation delay regardless of the input sampling frequency. There is no external synchronization mode. The amplified controller's clock always runs using its high-precision internal quartz at 96 kHz. This ensures low jitter and high audio quality in live conditions (large cable lengths, large number of amplified controllers) while preventing phase shift, as required for line source systems.

Digital domain benefits

Keeping the signal in the digital domain will provide the following benefits (with any digital mixing desk or any audio network) compared to the analog signal distribution:

- Better audio quality by removing one D/A - A/D cycle.
- Better dynamics thanks to the digital links' immunity to ground loops.
- Optimized level chain by removing the risk of level misalignment between console and amplified controllers.
- Digital signal refreshed at each amplified controller in a daisy-chain.
- Improved maximum cable length. The LA4X has been tested with up to **305 m/1000 ft** of 3 models of AES/EBU rated cables: Belden® 1696A, Klotz Cables® OT234H, and Sommer Cable® SC BINARY 234 (single cuts, digital source signal running at $F_s = 48$ kHz).

2.2.2 DSP architecture

The proprietary algorithms allow optimum performance and protection of each individual transducer of the L-Acoustics® systems for an even more natural, transparent and realistic sound experience.

- The DSP engine is a 32-bit floating point DSP at 96 kHz sampling rate providing an enhanced dynamic range since it does not generate calculation clips like a fixed point DSP.
- A dedicated engineering approach combining IIR and FIR filters generates perfectly linearized phase curves and significantly improved impulse responses.
- The 4 x 4 matrix architecture offers flexibility for various system configurations.
- A delay of up to 1000 ms can be set for each output channel.
- The L-DRIVE transducer protection system offers advanced protection by simultaneously monitoring the excursion and the temperature of the transducer.
- With a complete factory preset library and the possibility to create additional user presets, the flash memory provides a quick access to all the usual L-Acoustics® speaker system configurations (refer to the **PRESET GUIDE**).

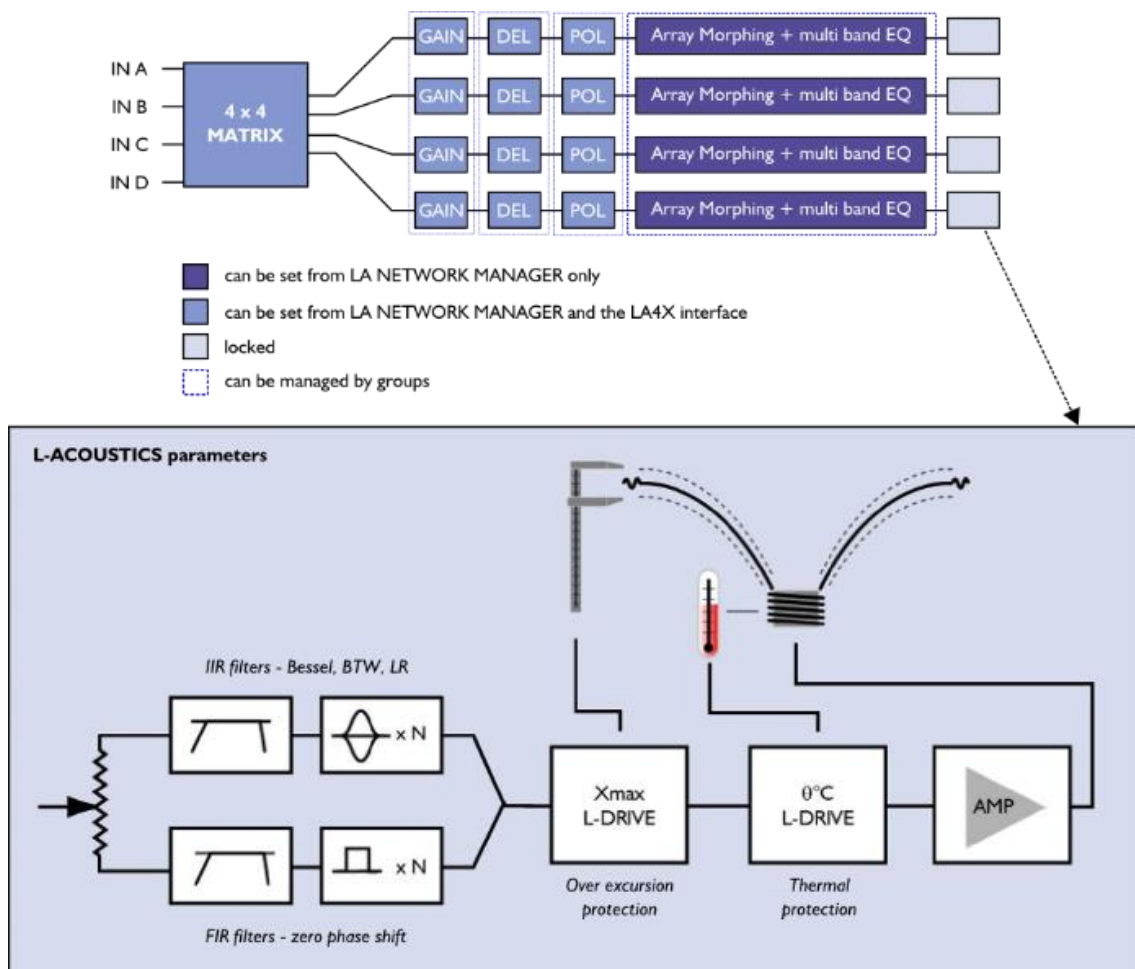

Figure 3: Audio path parameters

LA4X Amplified Controller

user manual

version 8.0

2.2.3 Power supply and amplifier section

LA4X is a “green” amplified controller that relies on a universal Switch Mode Power Supply (SMPS) suitable for mains from 100 to 240 V ($\pm 10\%$). The SMPS features a Power Factor Correction (PFC) which maximizes the amplifier efficiency and takes advantage of nearly 100 % of the electrical power available with a very high tolerance to unstable mains. The PFC allows the LA4X to deliver as much power from a 10 A line as from a 16 A line on a conventional amp. This represents a reduction of the electrical power requirements (cable gauge, power conditioning, etc.) for substantial savings.

The Class D amplification circuits ensure the LA4X energy-efficiency for minimal heat dissipation. LA4X delivers 4 x 1000 W RMS into 8 or 4 Ω with record hold times. Besides the high raw power rating at 8 Ω , the ability to deliver energy (power x hold time) yields the best performance from loudspeaker systems, especially in LF reproduction.

2.2.4 Speaker outputs

The LA4X features four SpeakON connectors for loudspeaker outputs.

2.3 Monitoring and control

2.3.1 User interface

The front panel user interface provides (see also Figure 2):

- Real-time monitoring functionalities via the LED display (signals presence and level) and the LCD screen (system parameters).
- Instant access to navigation and parameters control using the encoder wheel and the six keys.



Operating instructions

Refer to section 4 for detailed operating instructions.

2.3.2 L-NET remote control network

The design of complex systems is made possible by the integration of the L-NET Ethernet-based network. Thanks to its high speed data transfer protocol of 100 Mbit/s, up to 253 amplified controllers can be controlled and monitored in real-time from LA Network Manager software.

Multiple network topologies such as daisy-chain, star and hybrid are quickly and easily configurable for full flexibility in the required system architecture. The computer running LA Network Manager and the amplified controllers are connected to each other using industry standard CAT5e U/FTP cables (or higher category) fitted with RJ45 connectors.

The LA4X connects to the network via the two EtherCON sockets located on its rear panel.



Operating instructions

Refer to the **LA Network Manager video tutorial** for detailed operating instructions.



Third party management solutions

L-Acoustics® provides SNMP support to facilitate the integration via third party control and monitoring systems. As a certified member of the CRESTRON® and Extron® partner programs, L-Acoustics® also provides software modules allowing control integration into their automation systems.

Crestron is a trademark or registered trademark of Crestron Electronics, Inc. in the United States, other countries or both.
Extron is a registered trademark of Extron Electronics.

3 INSTALLATION

3.1 Mounting

The LA4X is two rack units high (2U) and can be mounted in an EIA-standard 19" rack (see Figure 4). The four points on the front panel are for rack mounting. Use the fixing material provided by the rack manufacturer to mount the controller to the rack front rails.

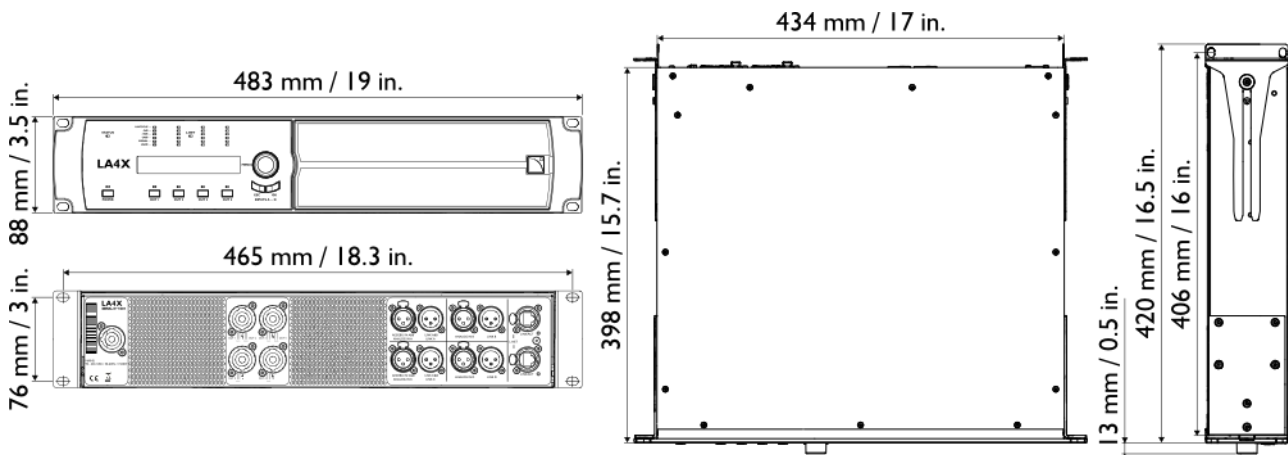

Figure 4: LA4X dimensions



Risk of damaging the controller during transport

During transport or while on tour it is essential that the controller is rear supported in addition to the front panel mounting.

Use the rear rack support brackets provided with the controller as shown in Figure 5.

Any mechanical damage to the controller used in portable applications without rear support will not be covered by warranty.

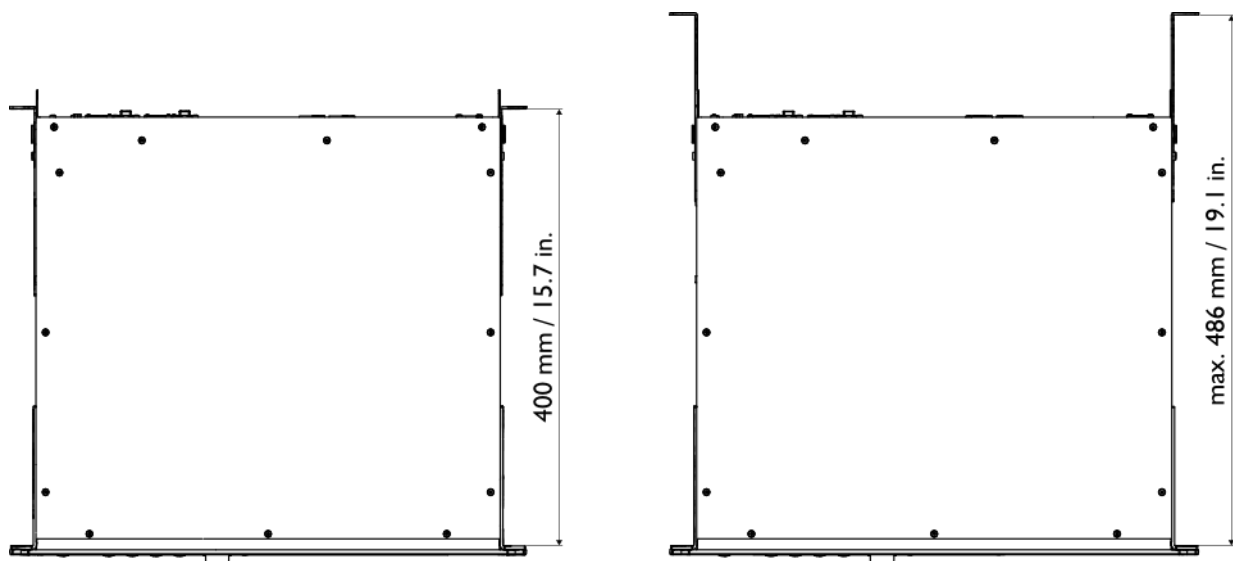

Figure 5: LA4X with rear rack support brackets

LA4X Amplified Controller

user manual

version 8.0

3.2 Ventilation

To maintain a moderate operating temperature, the LA4X contains two fans providing front to rear airflow.



Instructions for proper ventilation

Install the controller in an open area so that the front and rear panels are located at a minimum distance of 30 cm from any external object or structure.

Ensure that the front foam filter is clean.

Do not block the front and rear ventilation grills on a controller.

If the controller is rack-mounted:

- Do not block the ventilation grills with front or back panels or doors. If not possible, use a forced ventilation system.
- When stacking more than one controller in a rack, mount them directly on top of each other or close any open space in the rack with blank panels.

3.3 Connecting to AC mains

3.3.1 AC mains specifications



Only connect the LA4X to an AC power outlet rated 100-240 V, 50-60 Hz, with the following current values: 20 A for 100-120 V, 10 A for 200-240 V.

The LA4X must be connected to a mains socket outlet with a protective connection to earth.

3.3.2 Three-phase circuit



Verify that each phase works, in particular the neutral one.

Balance the loads between the three phases.

Never try to reproduce a 230 V circuit connecting an apparatus to two live wires of a 120 V three-phase circuit.

Never try to reproduce a 200 V circuit connecting an apparatus to two live wires of a 100 V three-phase circuit.

3.3.3 Circuit breaker



Always interconnect a Class C thermal circuit breaker between the apparatus and the mains supply.

The circuit breaker current rating depends on the mains voltage rating as follows:

20 A for 100-120 V, 10 A for 200-240 V.

3.3.4 Electrical generator

Planning the power of the generator in kVA

Consider the LA4X will draw 10 A max from 230 V.

A typical generator has a power factor $\cos \varphi = 0.8$ and should operate at 70 % load for good efficiency.

The kVA provision for one LA4X should therefore be: $(10A \times 230V) / (0.8 \times 70\%) = 4.1 \text{ kVA}$.

3.3.5 Power cord

The LA4X is supplied with a removable power cord. One side of the power cord is fitted with a 20A PowerCON connector to connect to the MAINS panel on the rear side of the controller, see Figure 6. The other side is fitted with a plug to connect to mains.

The plug type depends on the country of use, according to the following table:

Table 1: Power cords for LA4X

Country	Plug type
Europe	CEE 7/7, 16 A / 250 V grounded
USA	NEMA 5-15, 15 A / 125 V grounded
China	GB1002 GB2099, 16 A
International	bare ends (local power plug to be fitted)

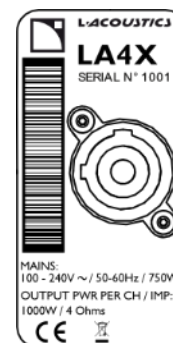

Figure 6: LA4X MAINS panel



Plug connection

Strictly apply the specific safety regulations of the country of use.

Do not defeat the ground connection of the supplied power cord using an adaptor or any other methods.

If the plug does not match the local power outlet, it can be cut off and wired to a suitable plug (refer to the **LA4X maintenance manual – level 1**).

Verify that the plug conforms to the specific voltage and current rating given in section 3.3.1.

To ensure the powerCON longevity:

- connect first the powerCON to the amplified controller, then the power plug to the mains socket
- disconnect first the power plug from the mains socket, then the powerCON from the amplified controller

3.3.6 Power consumption

The LA4X power requirements depend on the load impedance and the signal level as indicated in the following table:

Table 2: LA4X mains input power and current draw

Maximum output power			Mains input power and current draw			
Load	Number of driven channels	Power per channel	1/3 max. output power (-5 dB)	1/8 max. output power (-9 dB)	IDLE	Standby
4 or 8 Ω	4	1000 W	7 A / 1600 W	3 A / 750 W	0.26 A / 60 W	< 0.1 A / 11 W

The current values are given for a mains rated at 230 V. Multiply by 2.3 for 100 V, 1.9 for 120 V or 1.15 for 200 V.



Output power references

A third of the maximum output power corresponds to the worst case scenario of a program source using highly compressed music or pink noise with amplifier driven to clip level.

An eighth of the maximum output power corresponds to a loud music program with a small dynamic range and 9 dB of headroom (IEC standard power rating).

LA4X Amplified Controller

user manual

version 8.0

3.3.7 Example of heat power calculation

Connect a 4 Ω load to each output channel of the LA4X: each channel can now deliver a power of up to 1000 W.

Consider a standard use at 1/8 of full power (9 dB headroom): the power delivered per channel is then $1000 / 8 = 125$ W, leading to a total power of $4 \times 125 = 500$ W for the LA4X.

According to Table 2 the LA4X power consumption is 750 W: the heat power produced is then $750 - 500 = 250$ W (difference between power consumption and output power).

3.4 Audio and network cabling

3.4.1 Connection panels

The LA4X rear side features three panels for audio and network cabling, see Figure 7:

- SPEAKER to connect loudspeakers.
- SIGNAL to connect analog and/or digital (AES/EBU or S/PDIF) audio sources and link the signals to another amplified controller.
- L-NET to connect to a network and be remote controlled from LA Network Manager software.

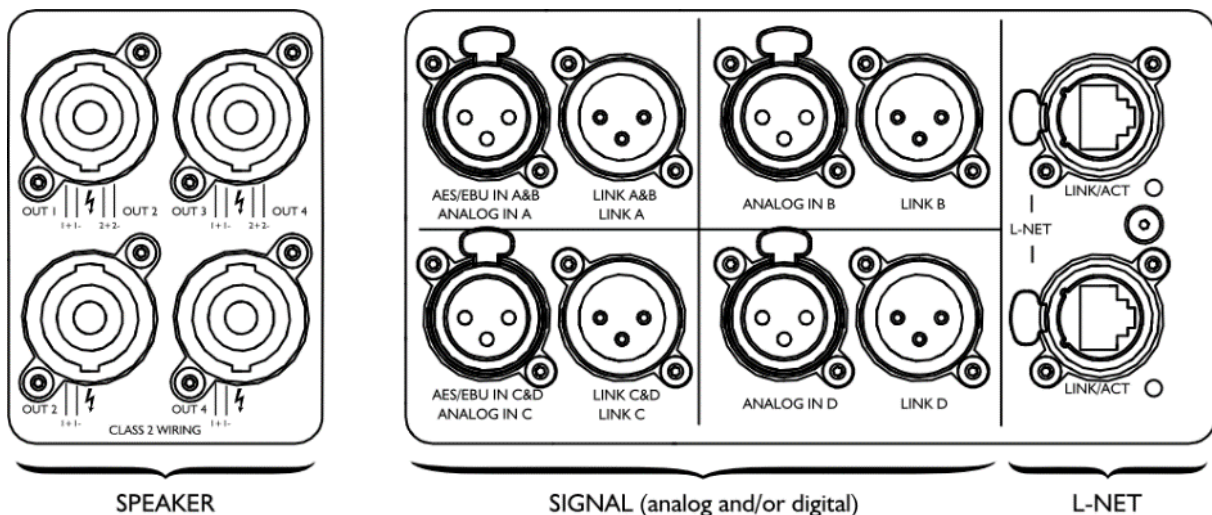

Figure 7: LA4X audio and network connection panels

The XLR connectors of the SIGNAL panel can transport analog or digital signals depending on the input mode selected by the user for channel pairs AB and CD (the two selections can be different). The devices to connect to the IN connectors are given in the following table (see also section 4.9.1 for input mode selection):

Table 3: Devices to connect to the IN connectors vs. input mode

Input mode AB	IN A (IN A&B)	IN B
ANALOG	analog audio source (1 channel)	analog audio source (1 channel)
AES/EBU	digital audio source (2 channels)	not used
Input mode CD	IN C (IN C&D)	IN D
ANALOG	analog audio source (1 channel)	analog audio source (1 channel)
AES/EBU	digital audio source (2 channels)	not used

Each LINK connector is wired to the corresponding IN connector and, thus, transports the same type of signal.

! Digital audio source specifications

Standard	AES/EBU (AES3) or electrical S/PDIF (IEC 60958 Type II)
Sampling frequency	44.1, 48, 64, 88.2, 96, 128, 176.4 or 192 kHz
Word length	16, 18, 20 or 24 bits.

3.4.2 Analog SIGNAL cabling

The eight XLR3 connectors of the SIGNAL panel (see Figure 7) are wired according to IEC 268: pin 1= shield, pin 2= + signal, pin 3= - signal.

The four female XLR3 input connectors ANALOG IN A to ANALOG IN D can receive up to four analog signals (when setting the analog input mode for channel pairs AB and CD). The headroom of the input circuits is high enough to accept the maximum output level from virtually any line level signal source (up to 22 dBu).

In a daisy-chain layout, the four male XLR3 link connectors LINK A to LINK D feed the input signals to the next amplified controller in the signal chain (see Figure 8). Each LINK connector is passively wired in parallel on the corresponding IN channel. The input impedance is high enough (22 k Ω , balanced) to allow multiple parallel input connections.

i Balanced cables

Symmetrical (balanced) shielded cables are highly recommended as balanced signals are less sensitive to AC hum and radio interference.

Unbalanced lines may add noise especially over long cable runs.

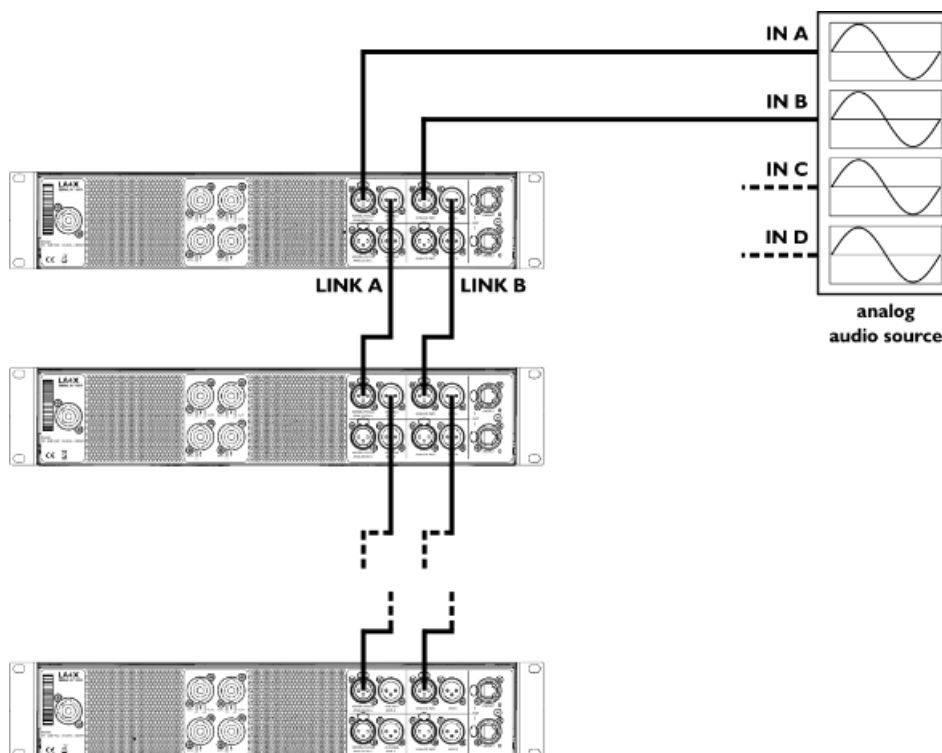

Figure 8: Daisy-chaining analog audio

LA4X Amplified Controller

user manual

version 8.0

3.4.3 Digital SIGNAL cabling

The four AES/EBU XLR3 connectors on the SIGNAL panel (see Figure 7) are transformer balanced and wired according to IEC 268.

The two female XLR3 input connectors AES/EBU IN A&B and AES/EBU IN C&D can receive up to four digital signals (when setting the AES/EBU input mode for channel pairs AB and CD). The input format is AES/EBU (AES3) or electrical S/PDIF (IEC 60958 Type II).

In a daisy-chain layout, the two male XLR3 link connectors LINK A&B and LINK C&D feed the input signals to the next amplified controller in the signal chain (see Figure 9). Each LINK connector is electronically buffered to allow daisy-chaining any number of amplified controllers. It also features a failsafe relay to ensure wiring continuity in case of amplified controller shutdown.



Cables for AES/EBU digital audio

AES3 specifies that the nominal characteristic impedance of cables used for AES/EBU digital audio transmission shall be $110 \Omega \pm 20\%$, and closer tolerances allow for increased transmission reliability over long lengths or higher sampling rates.

Therefore, it is highly recommended to use high-quality AES/EBU rated cables only, although certain cables designed for balanced analog audio prove to be acceptable at 48 kHz sampling rate over short distances.

It is recommended to use single cuts of cable between AES/EBU outputs and inputs. Using several pieces reduces performances. If it is not possible to use single cuts, it is required to use the same model of cable between two AES/EBU interfaces.

In case an amplified controller shuts down, the failsafe relay makes a passive connection between the AES/EBU IN ports and the LINK ports to maintain continuity. However the signals are no longer refreshed for the next amplified controller, so that the input cable and the link cable must be considered as a unique input cable with regard to the maximum supported length.

In case of transmission losses, try to reduce the sampling frequency of the digital audio source. Moreover, as a general rule, avoid using sources rated beyond 96 kHz, as the maximum possible cable length is reduced, while the additional information is cancelled by SRC to 96 kHz.

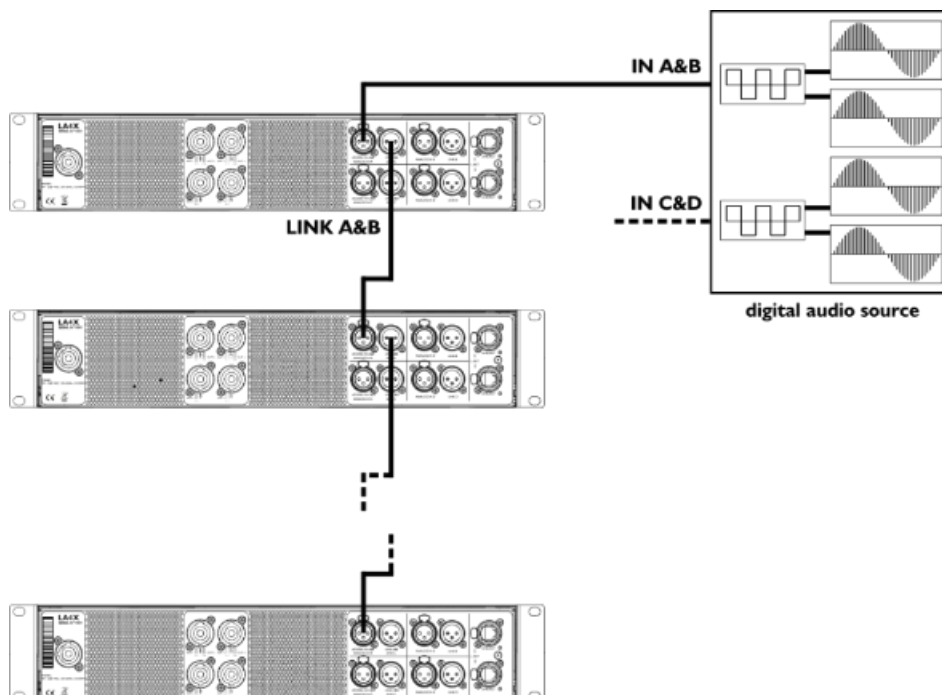

Figure 9: Daisy-chaining digital audio

3.4.4 SPEAKER cabling



Loudspeaker system connection

Before connecting a loudspeaker system refer to the applicable **user manuals** for further instructions.

The four 4-point SpeakON® connectors on the SPEAKER panel (see Figure 7) are for loudspeaker connection. They are wired as follows, see also Figure 10:

Top left SpeakON® connector		Top right SpeakON® connector	
Pin 1+	Out 1+	Pin 1+	Out 3+
Pin 1-	Out 1-	Pin 1-	Out 3-
Pin 2+	Out 2+	Pin 2+	Out 4+
Pin 2-	Out 2-	Pin 2-	Out 4-

Bottom left SpeakON® connector		Bottom right SpeakON® connector	
Pin 1+	Out 2+	Pin 1+	Out 4+
Pin 1-	Out 2-	Pin 1-	Out 4-
Pin 2+	not used	Pin 2+	not used
Pin 2-	not used	Pin 2-	not used

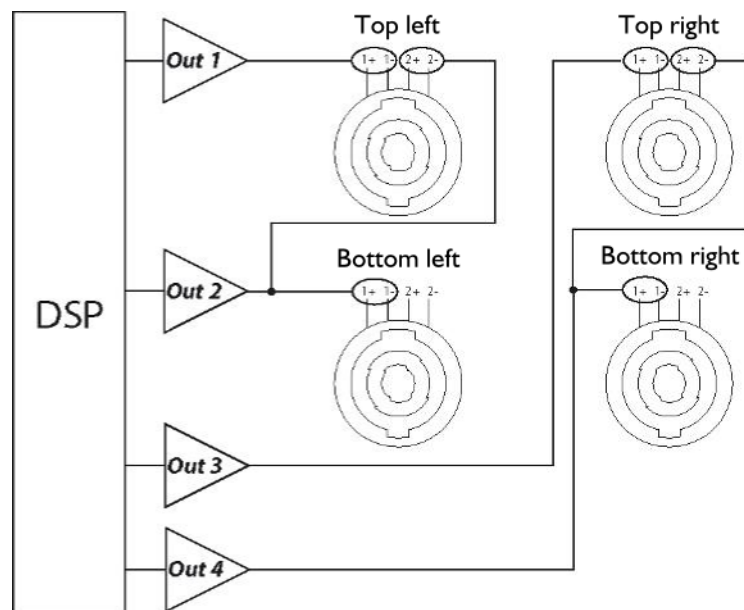

Figure 10: Output audio paths

LA4X Amplified Controller user manual

version 8.0

The table below describes the maximum number of enclosures a single LA4X amplified controller can drive.

Table 4: Maximum number of enclosures per LA4X

Technology	Loudspeaker enclosure	Max number of connections per output *	Max number of enclosures per controller
Coaxial	5XT	4	16
	8XT	2	8
	Active 12XT	2	4
	Passive 12XT	1	4
	115XT HiQ	1	2
	X8	2	8
	X12	1	4
Constant Curvature WST	X15 HiQ	1	2
	ARCS® Wide/Focus	1	4
Variable Curvature WST	ARCS® II	1	2
	Kiva / Kilo	2	8
	Kara®	2	4
	Kudo®	1	1
Subwoofers	K2	1	1
	SB15m	1	4
	SB18	1	4

* For passive loudspeakers, the value corresponds to the number of enclosures in parallel on the output.
For active loudspeakers, the value corresponds to the number of sections in parallel on the output.



For ARCS, SB118, the MTD series, 112XT and 115XT, refer to the enclosure drive capacity table of the **LA4** amplified controller.

3.4.5 L-NET cabling

The LA4X can be remote controlled over an Ethernet network (called L-NET) using LA Network Manager software (refer to the **LA Network Manager video tutorial**).

To connect the LA4X to L-NET use the EtherCON connectors on the L-NET panel (see Figure 7). Each of the two EtherCON connectors can be equally used as an IN or LINK connector.

Refer to the **LA Network Manager video tutorial** for network setup (type of cables, physical connections, network topology, etc.).



Do not create loops in the network setup



LA4X amplified controllers should always be placed before LA4 and LA8 amplified controllers in daisy-chain networks.

LA4 and LA8 amplified controllers are equipped with former generation 100 Mb/s Ethernet ports that cannot communicate with Ethernet ports of different capabilities, creating detection issues in LA Network Manager.

LA4X Amplified Controller user manual

version 8.0

4 OPERATION

4.1 Powering on, powering off, selecting the standby mode

- ▶ Press the **POWER** key for one second to power on the controller, see Figure 11.

The controller goes through a 6-second start-up sequence coming with **Initializing Controller** displayed on the LCD screen. The **POWER** LED turns off and then is lit in orange.

The controller is ready for use when the main screen is displayed and the **POWER** LED is lit in green (see section 4.2.1).



Figure 11: Start-up sequence

- ▶ Press the **POWER** key for one second to power off the controller.

The LCD screen and all LED turn off, except the **POWER** LED which turns red to indicate that the controller is not disconnected from mains (see Figure 12). Although it cannot be detected anymore over the network, the controller still transmits Ethernet data in a daisy-chain topology.

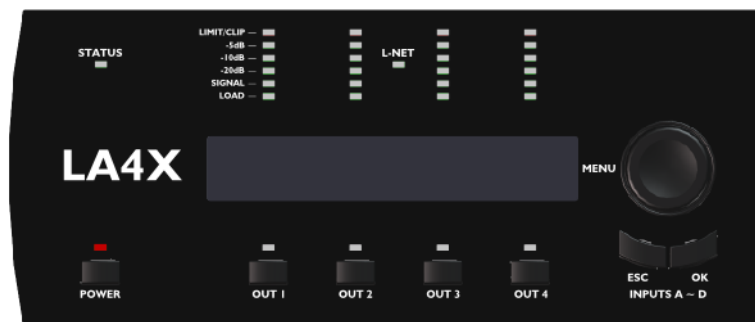

Figure 12: LA4X turned off

- i Power loss**
If the power has been lost the controller will shut down but all parameters will be restored to same state as before shutting down when the controller switches on again.
- ⚡ Disconnection from mains**
Powering off the controller does not disconnect it from mains.
- i Standby mode**
To reduce the electrical consumption and lock the front panel interface, the controller can be put in standby mode from LA Network Manager (refer to the **LA Network Manager video tutorial**). While the controller is in standby mode, **Standby Mode** is displayed on the LCD screen and the **POWER** LED is lit in orange.
It is possible to cancel the standby mode from LA Network Manager or from the controller front panel interface (▶ push and hold the encoder wheel for one second).

4.2 Display

4.2.1 Main screen

Once the start-up sequence has cycled (see section 4.1), the **POWER** LED is lit in green and the LCD displays the main screen shown in Figure 13:



Figure 13: Main screen

1. Low latency symbol
Indicates loaded preset is a low latency preset (refer to the **LA Network Manager video tutorial**).
2. Preset memory number (001 to 255): memory space containing the current preset
The preset can be a user preset or come from an on-board preset library (see section 4.4)
3. Preset name as in the preset library or as entered by the user (if stored as a user preset)
4. Last number in the IP address (1 to 254)
Identifies the controller within the L-NET network (see section 4.11.1)
5. Star sign: indicates that parameters have been modified after the preset was last stored (see section 4.5)
6. Output name and input selection, placed above each output key, written in the **xx_y** format where:
 - **xx** indicate the type of transducer section or enclosure to be connected to the output channel:
 - LF** low frequency transducer section part of a 2 or 3-way loudspeaker enclosure
 - MF** mid frequency transducer section part of a 3-way loudspeaker enclosure
 - HF** high frequency transducer section part of a 2 or 3-way loudspeaker enclosure
 - PA** passive loudspeaker enclosure
 - SB** subwoofer enclosure installed with front face pointing towards the audience
 - SR** subwoofer enclosure installed with front face pointing towards the direction opposite from the audience (part of a cardioid configuration)
 - **y** indicates the input selection of the output channel (input channel or input channels combination selected to drive this output channel, see also section 0):
 - A** IN A
 - B** IN B
 - A+** sum of IN A and IN B (A+B)
 - A-** difference between IN A and IN B (A-B)
 - C** IN C
 - D** IN D
 - C+** sum of IN C and IN D (C+D)
 - C-** difference between IN C and IN D (C-D)
 - X** Sum of IN A, IN B, IN C and IN D (A+B+C+D)

LA4X Amplified Controller

user manual

version 8.0

4.2.2 LED meters

Four LED meters are located on the front panel above the LCD screen (see Figure 14).



Figure 14: The four LED meters

By default the LED meters monitor the state of the four output channels via six LED:

LIMIT/CLIP is lit in:

- orange when the limiter is activated (the output voltage is attenuated).
- red when the output voltage reaches the maximum level (signal clip).

-5dB
-10dB
-20dB

are lit in green when the output voltage reaches respectively 5, 10 and 20 dB below the maximum level.

SIGNAL is lit in green when a signal is detected at the corresponding output of the amplified controller and when the output voltage reaches 0.1 V.

LOAD is lit in green when a load is connected and when the output module delivers a minimum of 0.8 sA.

4.2.3 STATUS and L-NET LED

The **STATUS** LED is lit in:

- green (see Figure 15) when the LA4X operates normally.
- red in case of firmware update or when a fault has been detected in the LA4X circuitry, indicating that a protection system is active (see Appendix A – Protection systems).

The **L-NET** LED is lit in green (see Figure 15) when the LA4X is remote controlled from software such as LA Network Manager (refer to the **LA Network Manager video tutorial**).



Front panel commands

The front panel commands remain accessible if the **L-NET** LED is lit.

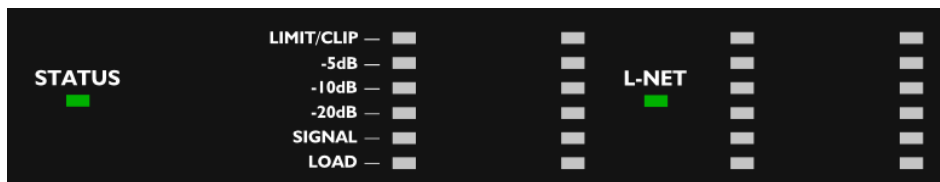

Figure 15: STATUS and L-NET LED

4.2.4 OUT LED

The **OUT_x** LED (see Figure 16) is:

- lit (when output channel OUT_x is muted).
- not lit (see Figure 16) when output channel OUT_x is unmuted.

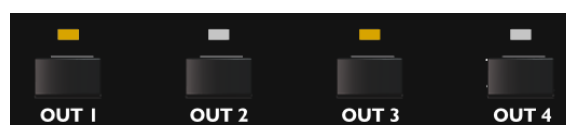

Figure 16: The four OUT LED

4.3 User interface

4.3.1 Quick access

The LA4X offers quick access functions for control (front panel locking, mute and gain), identification and monitoring (display of the input level, input selection, input mode and group information).

Lock/Unlock control

- ▶ To lock the front panel (even the mute function) and prevent unintentional operation, press and hold the **ESC** and **OK** keys simultaneously until **Display Locked** is displayed on the LCD screen (see Figure 17).
- ▶ To unlock, press and hold the **ESC** and **OK** keys simultaneously until **Display Unlocked** is displayed on the LCD screen.



Figure 17: Locking the front panel

Mute control

- ▶ Tap one of the four output keys holding it less than 0.3 sec to mute or unmute the corresponding output channel.

The **MUTE OUT** page is displayed for 2 seconds (see Figure 18).

- i** The output LED is lit when the corresponding output channel is muted and not lit when unmuted. The quick access mute control is available at all times and positions in the menu tree. Outputs are muted by default in all factory presets. The gain can be set before unmuting.



Figure 18: Unmuting OUT 1

LA4X Amplified Controller user manual

version 8.0

Gain control

In quick access mode, gain control applies for sets of output channels having input channels in common in their input selections (see also section 4.2.1). The gain control procedure is the following:

1. From the main screen, press and hold the chosen output key **OUTx**.
The LCD displays the gain values of all output channels having in their input selection an input channel in common with the input selection of **OUTx**.
2. Turn the encoder wheel to modify the gain values and simply release the key to return to the main screen.



Figure 19: Setting the OUT 3 gain



Additional information about gain control

Quick access gain control is only available from the main screen.

Gain values can be set by step of 0.1 dB (▶ turn the encoder wheel) or by step of 1 dB (▶ simultaneously press and turn the encoder wheel).

Examples of output channels routed to the same input, see Figure 20:

- Pressing **OUT1** will select OUT1, OUT3 and OUT4 (containing A).
- Pressing **OUT2** will select OUT2, OUT3 and OUT4 (containing B).
- Pressing **OUT3** or **OUT4** will select all channels (containing A or B).

Individual gain settings are available from the **PRESET PARAMETERS** menu (see section 0).



Figure 20: Multiple input selections

Identification

If the controller is connected to an L-NET network, it can be identified among other controllers in the workspace of LA Network Manager (refer to the **LA Network Manager video tutorial**).

- ▶ Press and hold the encoder wheel from the main screen to launch the identification.

The controller flashes in yellow in the workspace of LA Network Manager.

While pressing the encoder wheel, the **L-NET** and **OUT** LED flash and the LCD screen displays **IDENTIFICATION** and the IP address of the controller (see Figure 21).



Figure 21: Launching the Identification function

Input level, input selection, input mode and group information

- ▶ Press and hold the **ESC** or **OK** key from the main screen.

The LED meters and the top line of the LCD screen display information about input channels IN A, IN B, IN C and IN D, respectively from left to right, see Figure 22.

The bottom line of the LCD screen indicates the group assignment of output channels OUT 1, OUT 2, OUT 3 and OUT 4, respectively from left to right, see Figure 22.



Figure 22: Pressing ESC or OK

The **SIGNAL** to **LIMIT/CLIP** LED indicate the level of the signal on the corresponding input channel. For example in Figure 22, the signal of channel IN A has a level of -10 dB, the signal of channel IN B has a level of -20 dB and channels IN C and IN D receive no signals.



Input voltage values

The **SIGNAL** LED is lit when the input voltage reaches -38 dBu (analog audio source) or -60 dBfs (digital audio source).

The **CLIP** LED is lit when the input voltage reaches 22 dBu (analog audio source) or -0.1 dBfs (digital audio source).

Reminder: -38 dBu = 10 mV and 22 dBu = 9.8 V.

The **LOAD** LED is lit if the corresponding input channel is part of the input selection of at least one output channel (see also section 4.2.1). For example in Figure 22, channel IN A and IN B are selected and channels IN C and IN D are not selected.

The top line of the LCD screen indicates the input mode and status of input channel pairs AB and CD (see also section 4.9.1). For example in Figure 22, pair IN A/IN B receives an AES/EBU signal of 44.1 kHz and pair IN C/IN D is configured to receive ANALOG signals. The brackets indicate that the input mode cannot be different between IN A and IN B or between IN C and IN D.

The bottom line of the LCD screen indicates the group assignment of the corresponding output channel (see also section 0). For example in Figure 22, channels OUT 1 and OUT 2 are linked by brackets, it means that they are assigned to the same group or set of group (if an output channel is assigned to several group, the group name is **mult_grp**), OUT 3 is not assigned to any group and OUT 4 is assigned to group **All**.

LA4X Amplified Controller user manual

version 8.0

4.3.2 Main menu

The main menu gives access to the pages listed in the following table. Refer to the corresponding sections for detailed instructions.



LA Network Manager software

All parameters in each amplified controller can also be set from LA Network Manager software (refer to the **LA Network Manager video tutorial**).

•

Table 5: Main menu description

Page	Functionalities	Section
LOAD PRESET USER	load a user preset (memories 1-10)	4.4
LOAD PRESET FACTORY	load a factory preset (memories 11-199)	
STORE PRESET	save the current preset (including the current settings) as a user preset (memories 1-10)	4.5
DELETE PRESET	delete a user preset (memories 1-10)	4.6
PRESET PARAMETERS	set the gain, delay, polarity, and input selection parameters	0
CLEAR GROUP PARAMS	remove the group parameters defined in LA Network Manager software (names, gains, delays and Contour EQs)	0
INPUT SETTINGS	set the input mode, fallback mode and AES/EBU gain	0
MONITORING & INFO	display real-time measured values: RMS output voltage and output temperature (in percentage of the maximum values) display the firmware and factory preset library versions display the controller's MAC address access the ENCLOSURE CHECK function	0
OPTIONS	set the controller's IP address set the delay unit, LCD screen contrast and light mode reset all parameters to factory defaults	4.11

To enter a page, follow these steps (see also Figure 23):

1. Press and release the encoder wheel.
2. Turn the encoder wheel clockwise or counterclockwise to select a page.
3. Press the **OK** key or the encoder wheel to enter this page or press the **ESC** key to return to the main screen.



On the LCD screen, two types of arrow cursors indicate how to navigate through the menus, see Figure 23:

Position cursors (on the left)

- ↓ Start of a menu. Other functionalities can be displayed turning the encoder wheel clockwise.
- ↻ Middle of a menu. Other functionalities can be displayed turning the encoder wheel clockwise or counterclockwise.
- ↑ End of a menu. Other functionalities can be displayed turning the encoder wheel counterclockwise.

Selection cursors (on the right)

- ↵ Another menu level or function can be accessed pressing the **OK** key or the encoder wheel.
Press the **ESC** key to return to the previous menu.
- ← No additional menu level or function exist.
Turn the encoder wheel to access another menu or press the **ESC** key to return to the previous menu.



Figure 23: Main menu

LA4X Amplified Controller user manual

version 8.0

4.3.3 Access rights, pin code

The functionalities indicated in the following table can be locked or protected by a 4-digit pin code defined from LA Network Manager (refer to the **LA Network Manager video tutorial**):

Table 6: Functionalities locked or protected by pin code

Functionality	Locked / Pin code protected
Quick access to gains on keys OUT1 to OUT4	Locked
LOAD PRESET FACTORY	Pin code protected
STORE PRESET	Pin code protected
DELETE PRESET	Locked
PRESET PARAMETERS (all parameters)	Pin code protected
CLEAR GROUP PARAMS	Pin code protected
NETWORK ADDRESS	Pin code protected
RESET TO FACTORY DEFAULT SETTINGS?	Locked

When the protection is enabled, each time one tries to use a protected functionality, the LCD screen displays **ACCESS LOCKED** or **ENTER PIN**, see Figure 24.



Figure 24: Lock and pin code protection messages

In the first case, the functionality cannot be accessed. Press the **ESC** key to abort.

In the second case, access the functionality entering the pin code as follows (see also Figure 25):

1. Press and hold the **OUT 1** key. Or press the **ESC** key to abort.
2. Turn the encoder wheel to select the first digit of the pin code.
3. Release the **OUT** key.
4. Repeat the procedure for keys **OUT 2** to **OUT 4** and the associated digits.
5. Press the **OK** key.

*If the controller returns to the ? ? ? ? page, it means that the pin code is wrong. Make corrections repeating the procedure. Or press the **ESC** key to abort.*

Else, the functionality is displayed and can be accessed until you leave the current menu.

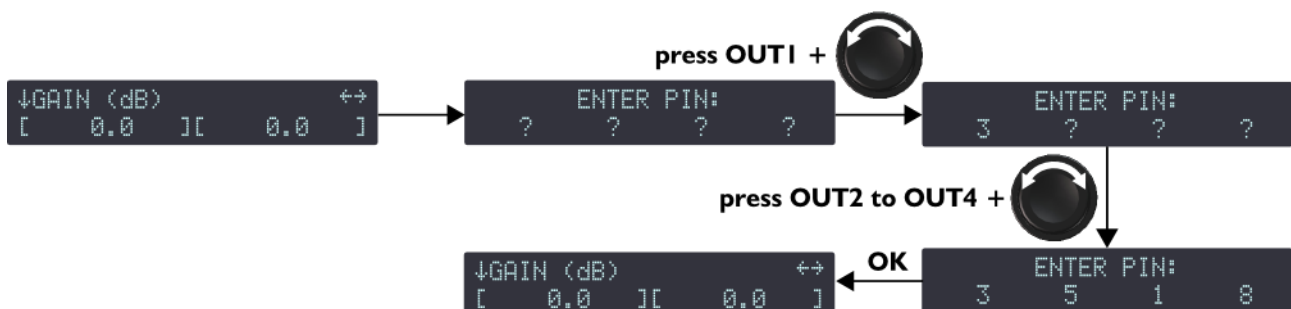

Figure 25: Entering a pin code

i Disabling the protection

You can disable the lock / pin code protection only from LA Network Manager entering the password defined for this amplified controller (refer to the **LA Network Manager video tutorial**).

4.4 LOAD PRESET

A preset can be loaded from the following menu pages:

Table 7: LOAD PRESET pages

Page	Memory range	Contents
LOAD PRESET USER	1 - 10 (read and write)	User presets stored by the user (see section 4.5).
LOAD PRESET FACTORY	11 - 199 (read only)	Factory preset library created by L-Acoustics® and automatically installed during firmware update (refer to the LA Network Manager video tutorial).

To load a preset, follow these steps (see also Figure 26):

- From the main menu, select **LOAD PRESET USER** or **LOAD PRESET FACTORY**.
If the controller displays **NO PRESETS AVAILABLE!** when you select **LOAD PRESET USER**, it means that all user memories are empty. Press the **ESC** key to abort. — **END** —
Else, continue the procedure.
- Turn the encoder wheel to scroll through the presets.
- Press the **OK** key or the encoder wheel to select a preset (or **ESC** to abort).
The controller displays **ARE YOU SURE?**
- Press the **OK** key or the encoder wheel to validate (or **ESC** to abort).
If the controller displays the main screen, it means that the preset has been successfully loaded.
— **END** —

If the controller displays **CLEAR GROUP PARAM? OUTPUTS MUTED!**, it means it is assigned to groups and is no longer connected to the L-NET network.

Either press the **OK** key to load the preset while clearing the group parameters

Or press the **ESC** key to load the preset while keeping the group parameters active. — **END** —

If the controller displays **GROUP CONFLICT! CLEAR GROUP PARAM?**, it means it is assigned to groups and there is a group conflict. Loading the preset is only possible while clearing the group parameters.

Either press the **OK** key to load the preset while clearing the group parameters

Or press the **ESC** key to load the preset while keeping the group parameters active. — **END** —

If the controller displays **GROUP CONFLICT! CANNOT LOAD PRESET**, it means it is assigned to groups and there is a group conflict but it is not possible to clear the group parameters as controller is connected to the L-NET network.

Press the **ESC** key to abort. — **END** —



Possible group conflicts:

The output channels are assigned to groups and the assignation structure is not compatible with the channel sets of the preset to be loaded.

Group parameters include enabled FIR filters (Zoom Factor, FIR1, FIR2, FIR3 or Air Absorption Compensation) and the preset to be loaded is a low latency preset.

LA4X Amplified Controller user manual

version 8.0

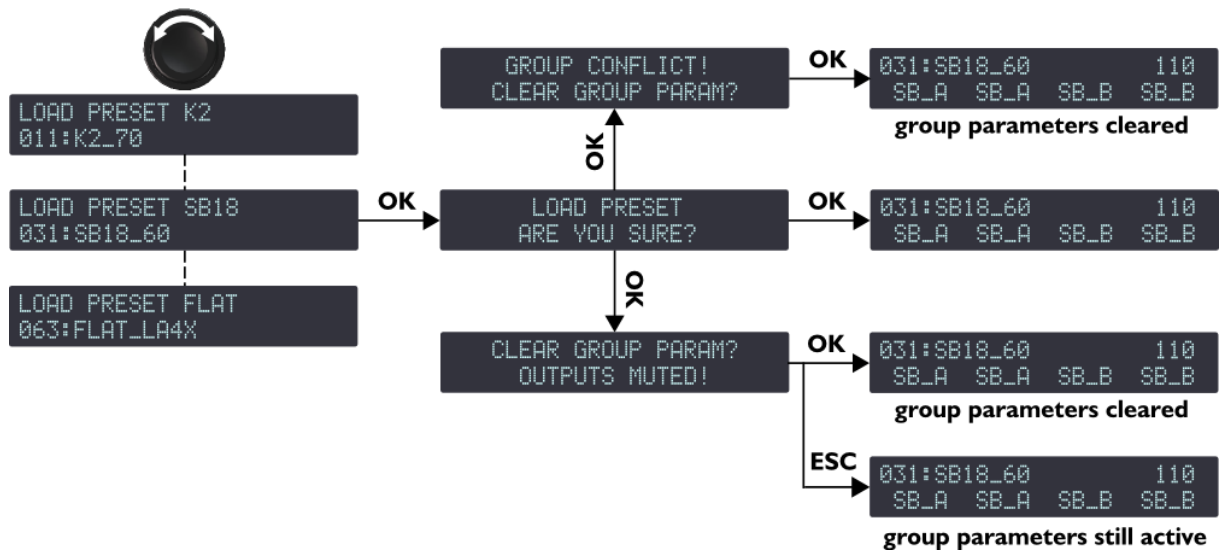

Figure 26: Loading a preset (example with a factory preset)



Complements about the LOAD PRESET screen

The upper line of the screen displays the preset family allowing coarse selection while the bottom line displays the preset name allowing preset selection within a family.

If the name of the displayed preset has been modified (user presets only), it is possible to display the original name pressing and holding the encoder wheel.

4.5 STORE PRESET

The current preset and the possible setting modifications can be stored to a user memory (**1-10**).

Modifications flag

The modifications of the preset parameters are indicated by a star sign (on the top right corner of the LCD screen) until the preset has been stored to a user memory or set to its initial settings.



There is a risk of losing the preset parameter modifications

Preset parameter modifications (see section 4.7) are not automatically saved to the current preset: they will be lost if the preset is reloaded prior to storing it (e.g. while the star sign is displayed). However, the current state is saved when the controller is shut down.

To store a preset follow these steps (see also Figure 27):

1. From the main menu select **STORE PRESET**.
2. Turn the encoder wheel to scroll through the user memories.
3. Press the **OK** key or the encoder wheel to select a user memory (or **ESC** to abort).
4. If the controller displays **OVERWRITE?** it means that a preset is already stored in the selected user memory.
Press the **OK** key or the encoder wheel to validate (or **ESC** to abort).
5. If necessary enter a new preset name (**16** characters max) as follows:
 - a. Turn the encoder wheel to select the first character.
 - b. Press the encoder wheel to go to the next character.
 - c. Repeat these steps until the new name has been entered.



Pressing the encoder wheel from the 16th character makes the cursor return to the first character so that it is possible to apply the procedure a new time for possible corrections.
6. Press the **OK** key to validate (or **ESC** to abort).
The preset is stored and the main screen is displayed.

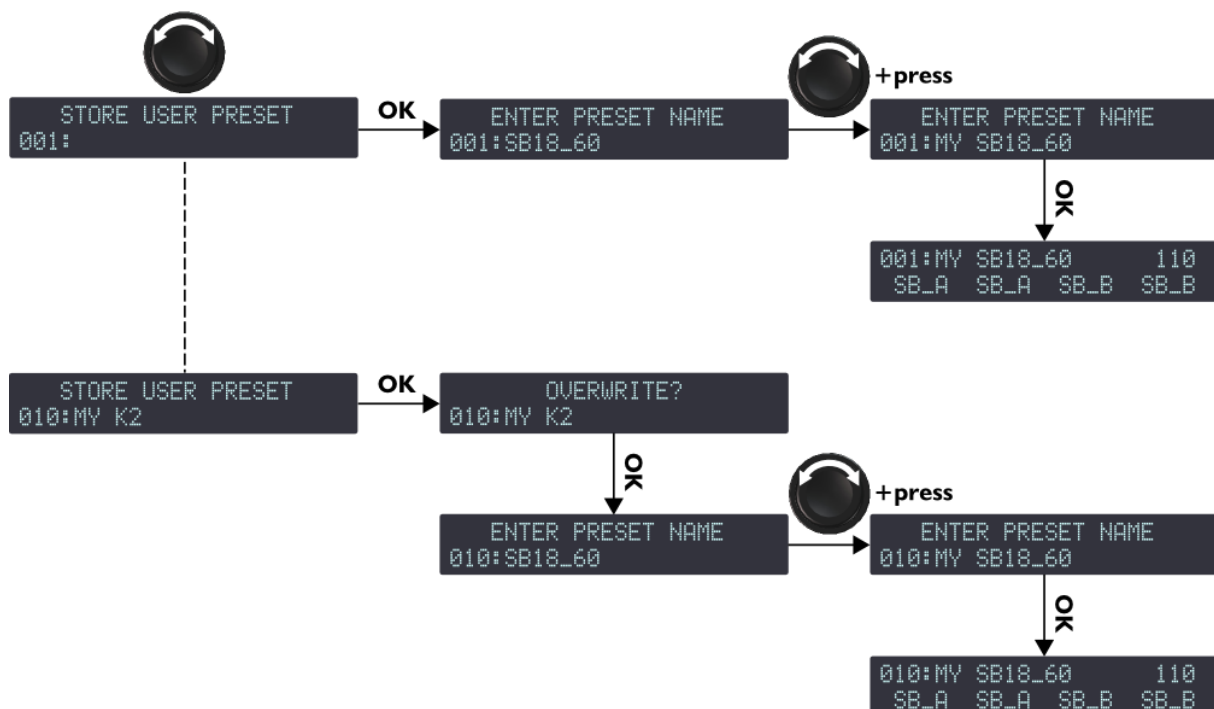

Figure 27: Storing a preset

LA4X Amplified Controller user manual

version 8.0

4.6 DELETE PRESET

A user preset contained in a user memory (**1-10**) can be deleted following these steps (see also Figure 28):

1. From the main menu select **DELETE PRESET**.
*If the controller displays **NO PRESETS AVAILABLE!** it means that all user memories are empty.
Press the **ESC** key to abort. — END —
Else, continue the procedure.*
2. Turn the encoder wheel to scroll through the user presets.
3. Press the **OK** key or the encoder wheel to select a preset (or **ESC** to abort).
The controller displays **ARE YOU SURE?**.
4. Press the **OK** key or the encoder wheel to validate (or **ESC** to abort).
*If the main screen is displayed it means that the selected preset has been deleted.
If the controller displays **CANNOT DELETE THE CURRENT PRESET** it means that the selected preset is the current preset thus it is not possible to delete it.
Press the **ESC** key to abort.*



Figure 28: Deleting a user preset

4.7 PRESET PARAMETERS

The preset parameters (gain, delay, polarity and input selection) of the current preset can be set individually for each output channel or channel set (see the following INFORMATION note).

i Channel set

In certain presets, some channels are interdependent and form what is called a channel set. Within a channel set the preset parameters are common to all channels.

On the LCD screen the channel sets are indicated by brackets displayed above the corresponding output channel keys. For example Figure 29 shows on the left a preset composed of two channel sets (LF/HF-LF/HF) for 2-way active loudspeakers, and on the right a preset composed of one 4-channel set (SR/SB/SB/SB) for 4 subwoofers in cardioid configuration.



Figure 29: Channel sets

To set the preset parameters follow these steps (see also Figure 30):

1. From the main menu select **PRESET PARAMETERS**.
2. Turn the encoder wheel to select a preset parameter.
3. Press and hold the chosen output key (or any output key of a channel set) and turn the encoder wheel to select a value (or press **ESC** to abort).
4. Release the key.
5. Repeat the procedure for each value to be set.
6. Press **ESC** to return to the main menu.

i If necessary all preset parameters (including the preset name) can be reset to default values following these steps (see also Figure 30):

1. Turn the encoder wheel to select **RESET PRESET**.
2. Press the **OK** key or the encoder wheel two times (or **ESC** to abort).

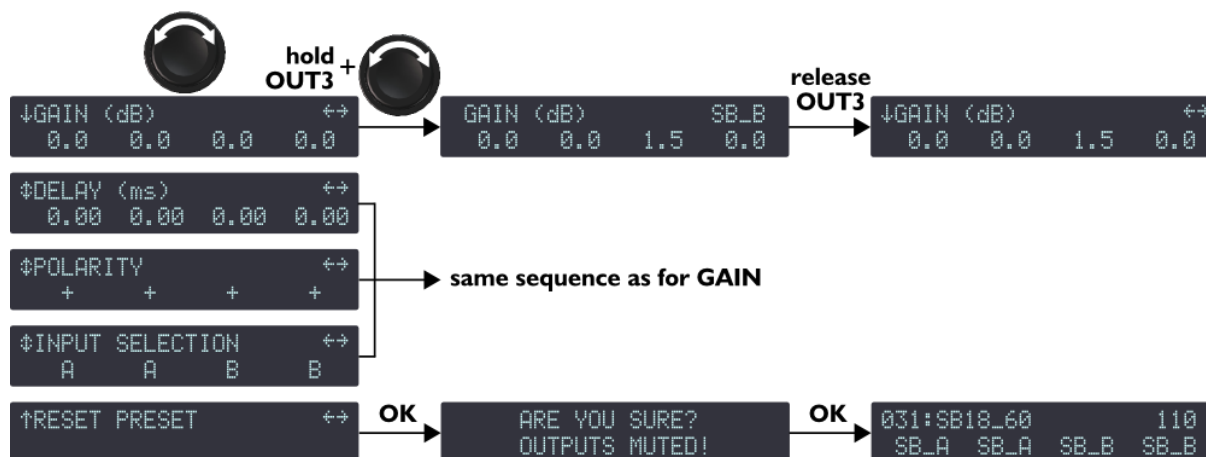

Figure 30: Setting the preset parameters

LA4X Amplified Controller

user manual

version 8.0



Resetting the parameters of a user preset (stored in memory space 001 to 010) only affects the current parameters.

To reset the parameters of a stored preset, overwrite the memory space after resetting the preset. Refer to section 4.5.



Value ranges

Gain values are adjustable between **-60 dB** and **+15 dB**.

Delay values are adjustable from **0** to **1000 ms** (96000 samples / 343.33 m / 1126.40 ft at 20 °C).

Refer to section 4.1.1.2 for setting the delay unit.



Value setting resolution

▶ Turn the encoder wheel to obtain fine resolution (last digit).

▶ Press and turn the encoder wheel to obtain coarse resolution (second to last digit).



Total delay

The total delay is the sum of the group delays (set in LA Network Manager) and the output channel delay. The total delay cannot exceed **1000 ms**.



Preset parameters saving

Preset parameter modifications apply immediately but are not automatically saved to the current preset (they will be lost if the preset is reloaded). Use the **STORE PRESET** function to save the current preset with its settings to a user memory (see section 4.5).

4.8 CLEAR GROUP PARAMS

The group parameters (names, gains, delays and contour EQs) defined in LA Network Manager (refer to the **LA Network Manager video tutorial**) can be cleared.

i Group and preset parameters

The group parameters apply to a set of amplified controllers that are part of groups while the preset parameters apply to a single amplified controller.

CLEAR GROUP PARAMS only clears the group parameters and does not clear the preset parameters.

To clear the group parameters follow these steps (see also Figure 31):

1. From the main menu select **CLEAR GROUP PARAMS**.
2. Press the **OK** key or the encoder wheel (or **ESC** to abort).
 - If the controller displays **L-NET ACTIVE. CANNOT CLEAR** it means that the operation is not allowed since the amplified controller is remote controlled. Press the **ESC** key to abort. — END —*
 - If the controller displays **NO GROUP DEFINED. CANNOT CLEAR** it means that the operation is not possible as no group are defined. Press the **ESC** key to abort. — END —*
 - If the controller displays **ARE YOU SURE? OUTPUTS MUTED!** it means that the operation can be continued and that all outputs will be muted as a precaution. Continue the procedure.*
3. Press the **OK** key or the encoder wheel (or **ESC** to abort).

The main screen is displayed, all group parameters are now reset and all outputs are muted.

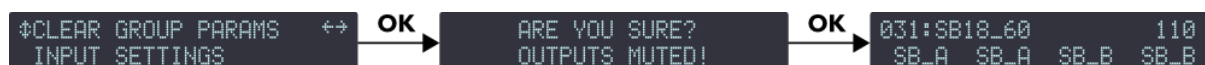

Figure 31: Clearing the group parameters

i Group parameters persistence

The group parameters remain active even if the controller is disconnected from the computer running LA NETWORK MANAGER (controller in the standalone mode), even if it is shut down and restarted. Moreover, the group parameters are not preset dependent: they will remain the same even if a new preset is loaded.

Therefore, when getting a controller for a standalone application that has been previously used within a network, L-Acoustics® recommends using the **CLEAR GROUP PARAMS** function to clear all group parameters as they cannot be seen and accessed via the front panel user interface.

i Group information

It is possible to verify if output channels of the controller are part of groups pressing and holding the **ESC** or **OK** key from the main screen (refer to section 4.3.1, group information).

LA4X Amplified Controller

user manual

version 8.0

4.9 INPUT SETTINGS

4.9.1 INPUT MODE

The XLR connectors of the SIGNAL panel (see section 3.4.1) can receive analog or digital signals, depending on the type of audio sources connected to them. The input mode function allows selecting the type of signal for channel pairs AB and CD.

i The input mode selection can be different between channel pairs AB and CD. But it cannot be different between input channels A and B, or C and D.

To select the input mode follow these steps:

1. From the main menu select **INPUT SETTINGS** and press the **OK** key or the encoder wheel (or **ESC** to abort).
2. Turn the encoder wheel to select **INPUT MODE AB** or **INPUT MODE CD**.
3. Press the **OK** key or the encoder wheel to enter the page (or **ESC** to abort).
4. Turn the encoder wheel to select **ANALOG** or **AES/EBU**.
5. Press the **OK** key or the encoder wheel to validate the setting (or **ESC** to abort).

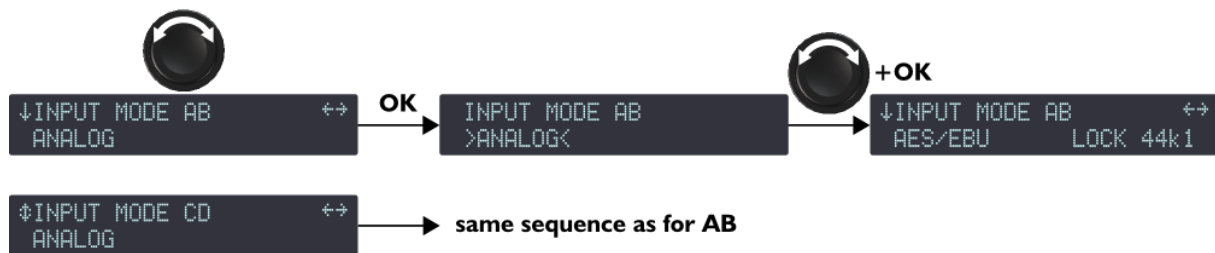

Figure 32: Selecting the input mode

In Figure 32 the AES/EBU input mode has been enabled. **LOCK 44k1** is a status message indicating that the AES/EBU input mode is active and that the digital audio source provides signals of sampling frequency of 44.1 kHz.

The LOCK status is obtained under the following conditions: a digital audio source is connected to the AES/EBU input, the signal delivered by the source has a format supported by the controller's digital audio card, and no loss or fault is being detected during data transfer.

If these conditions are not fulfilled the status turns to **LOCK-WARN** or **UNLOCK**. The LOCK-WARN status (Figure 33 left) indicates that the incoming digital signal has a sampling frequency out of the nominal range, that does not lead to sound cut. On the contrary, the UNLOCK status (Figure 33 right) indicates a faulty digital signal leading to sound cut.

The **LOCK** status is recovered after at least 500 ms of stability.



Figure 33: LOCK-WARN and UNLOCK statuses

Sound cut can be avoided using the **FALLBACK MODE** on channel pair AB and a backup audio source connected to channel pair CD (refer to section 4.9.2). In case of UNLOCK status the CD inputs will automatically be selected, leading to one of the screens of Figure 34. **FALLBACK (CD)** indicates that the amplified controller has switched from inputs AB to CD. The text displayed on the right (**UNLOCK**, **LOCK-WARN**, or **LOCK 44k1**) informs the user about the status of the digital audio source connected to AB.



Figure 34: FALLBACK statuses

When the LOCK status has been recovered, the user can manually reactivate channel pair AB applying the sequence described in Figure 35:

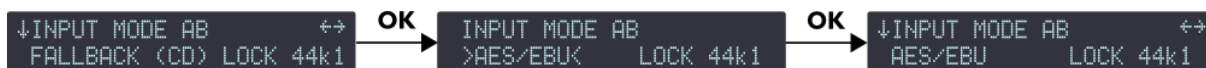

Figure 35: Reactivating channel pair AB

In case of non-audio data in the payload or errors in the AES/EBU transmission, the status is **INVALID**.

LA4X Amplified Controller

user manual

version 8.0

4.9.2 FALLBACK MODE

An automatic fallback option can be enabled or disabled. When enabled, and when the AES/EBU input mode is selected for input pair AB, the amplified controller will automatically switch from input pair AB to input pair CD in case of digital signal failure on input pair AB (no clock, loss of lock, CRC error, bipolar encoding error, data slip). This option prevents sound cut.

After the digital signal has returned to normal state, reverting to input pair AB is not automatic and must be done manually by the user. This can be done simultaneously for all concerned amplified controllers from LA Network Manager software.



Precautions for using the automatic fallback option

Before enabling the automatic fallback option, some precautions have to be taken in order to avoid sound cut or level differences in case of switch from input pair AB to input pair CD:

- Input pair CD must be connected to an audio source (analog or digital) playing the same program as the digital audio source connected to input pair AB.
- When an analog audio source is connected to input pair CD, the level of the digital audio source connected to input pair AB must be aligned to the level of the analog audio source using the AES/EBU GAIN control (see section 4.9.3).

Two FALLBACK MODE settings are available, as described in the following table:

Table 8: FALLBACK MODE settings

OFF	Automatic fallback option disabled. The sound will be cut off in case of digital signal failure on input pair AB, but it will automatically be recovered when the signal has returned to normal state.
ON	Automatic fallback option enabled. Input pair CD will automatically be selected in case of digital signal failure on input pair AB. Revert to input pair AB is not automatic and must be done manually by the user.

To select the fallback mode follow these steps (see also Figure 36):

1. From the main menu select **INPUT SETTINGS** and press the **OK** key or the encoder wheel (or **ESC** to abort).
2. Turn the encoder wheel to select **FALLBACK MODE**.
3. Press the **OK** key or the encoder wheel to enter the page (or **ESC** to abort).
4. Turn the encoder wheel to select the chosen setting.
5. Press the **OK** key or the encoder wheel to validate the setting (or **ESC** to abort).



Figure 36: Selecting the fallback mode



Invalid audio (validity bit)

Validity bit does not trigger the automatic fallback. Instead the signal is muted.

4.9.3 AES/EBU GAIN

The AES/EBU input ports include a gain module, common to all ports, which can be set from -12 dB to +12 dB by 0.1 dB steps. It must be used when the fallback mode is enabled, a digital audio source is connected to input pair AB and an analog audio source is connected to input pair CD. The AES/EBU GAIN allows aligning the digital audio source level to the analog level value so as to ensure seamless fallback switch from AES/EBU to analog inputs in case of fallback mode activation (refer to section 4.9.2).

The AES/EBU GAIN must be set according to the analog audio source's calibration (based on manufacturer's specs or user measurements) and the amplified controller's analog inputs calibration (0 dBfs for an input signal of +22 dBu). The three following examples illustrate the most common cases:

- If the analog audio source is calibrated at +18 dBu for 0 dBfs, set the AES/EBU GAIN to -4 dB.
- If the analog audio source is calibrated at +24 dBu for 0 dBfs, set the AES/EBU GAIN to +2 dB.
- If the analog audio source is calibrated at +22 dBu for 0 dBfs or if the fallback option is disabled or if a digital audio source is connected to input pair CD, set the AES/EBU GAIN to +0 dB.

To set the AES/EBU GAIN follow these steps (see also Figure 37):

1. From the main menu select **INPUT SETTINGS** and press the **OK** key or the encoder wheel (or **ESC** to abort).
2. Turn the encoder wheel to select **AES/EBU GAIN**.
3. While holding the **ESC**, **OK** or **OUT1** key, turn the encoder wheel to select an input gain value and release the key.

The setting applies in real-time when turning the encoder wheel.

Value setting resolution

- ▶ Turn the encoder wheel to obtain a 0.1-step resolution.
- ▶ Press and turn the encoder wheel to obtain a 1-step resolution.

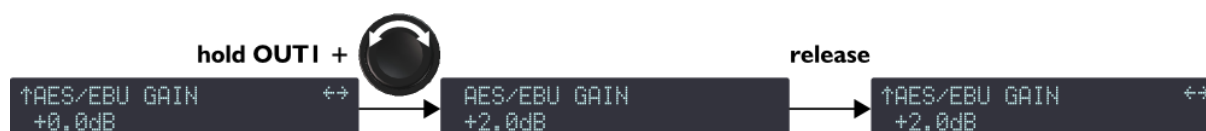

Figure 37: Setting the AES/EBU GAIN

LA4X Amplified Controller

user manual

version 8.0

4.10 MONITORING & INFO

This menu provides real-time measurements to monitor the output channels and provides the versions of embedded software. In more details, the **MONITORING & INFO** menu allows to:

- Display in real-time the RMS output voltage and output temperature for each output channel. The output voltage is given in percentage of the maximum value supported by the particular transducer section connected. The temperature is given in percentage of the operating range.
- Display the firmware and factory preset library versions.
- Display the controller's MAC address.
- Display the controller's hardware version.
- Access to the **ENCLOSURE CHECK** function.

Figure 38 shows all pages of the **MONITORING & INFO** menu. Each page is detailed in sections 4.10.1 to 4.10.7.

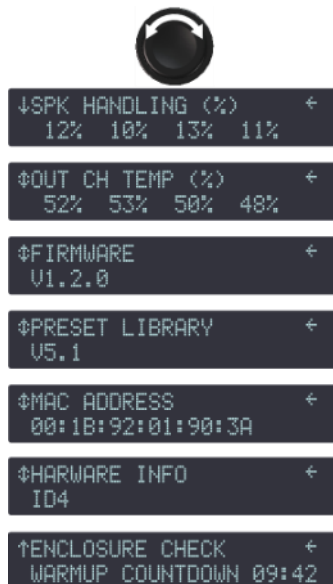

Figure 38: MONITORING AND INFO menu pages

4.10.1 SPK HANDLING

This page displays the RMS voltage measured at each individual amplifier circuit output as a percentage of the maximum voltage supported by the particular speaker section connected to it.

For example, in Figure 38 the RMS voltage of channels **OUT 1** to **OUT 4** is respectively 12, 10, 13, and 11 % of the maximum values.

4.10.2 OUT CH TEMP

This page displays the temperature of each individual amplifier channel circuit as a percentage of the maximum operating temperature: $60^{\circ}\text{C} = 100\%$.

For example, in Figure 38 the temperature of channels **OUT 1** to **OUT 4** is respectively 52, 53, 50, and 48 %.

4.10.3 FIRMWARE

This page displays the version of LA4X firmware in use in the controller.

For example, Figure 38 shows LA4X firmware version **1.2.0**.

Press the encoder wheel to display the full version number and the build date (format is YYYYMMDD).



Figure 39: Displaying the full firmware version number and build date



Network

Always ensure that all LA4X controllers used in a given network run the same firmware version.

4.10.4 PRESET LIBRARY

This page displays the version of the preset library in use in the controller.

For example, Figure 38 shows preset library version **5.1**.

Press the encoder wheel to display the full version number.

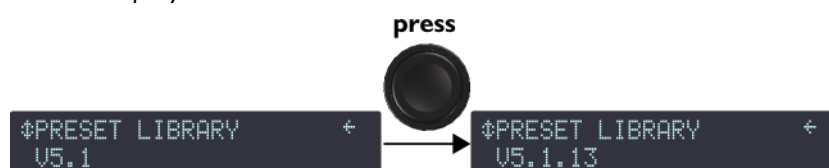

Figure 40: Displaying the full preset library version number



PRESET LIBRARY description

Refer to the **PRESET GUIDE** for full description of the factory presets.

4.10.5 MAC ADDRESS

This page displays the MAC (Media Access Control) address of the amplified controller. This address (unique to each controller) is the equivalent of a serial number and identifies the controller internationally. It is set by the manufacturer and cannot be modified.

For example, in Figure 38 the MAC address is **00:1B:92:01:90:3A**.

4.10.6 HARDWARE INFO

This page displays the version number of the hardware in use in the controller. For troubleshooting purposes, it can be useful to communicate this number to the L-Acoustics® representative.

For example, in Figure 38 the hardware has **ID4**.

4.10.7 ENCLOSURE CHECK

This page gives access to the **ENCLOSURE CHECK** function, a preliminary diagnosis tool for the loudspeaker enclosures connected to the controller.



How to use ENCLOSURE CHECK

Refer to the **ENCLOSURE CHECK Technical Bulletin** for a full description of the procedure.

LA4X Amplified Controller user manual

version 8.0

4.11 OPTIONS

This menu allows setting the amplified controller's general parameters. These parameters are the following:

- IP address.
- delay unit (ms, meters, feet or samples).
- LCD screen contrast.
- LED and LCD screen backlight mode.

An additional function allows resetting the amplified controller to its factory default state.

Figure 41 shows all pages of the **OPTIONS** menu. Each one is detailed in sections from 4.11.1 to 4.11.5.

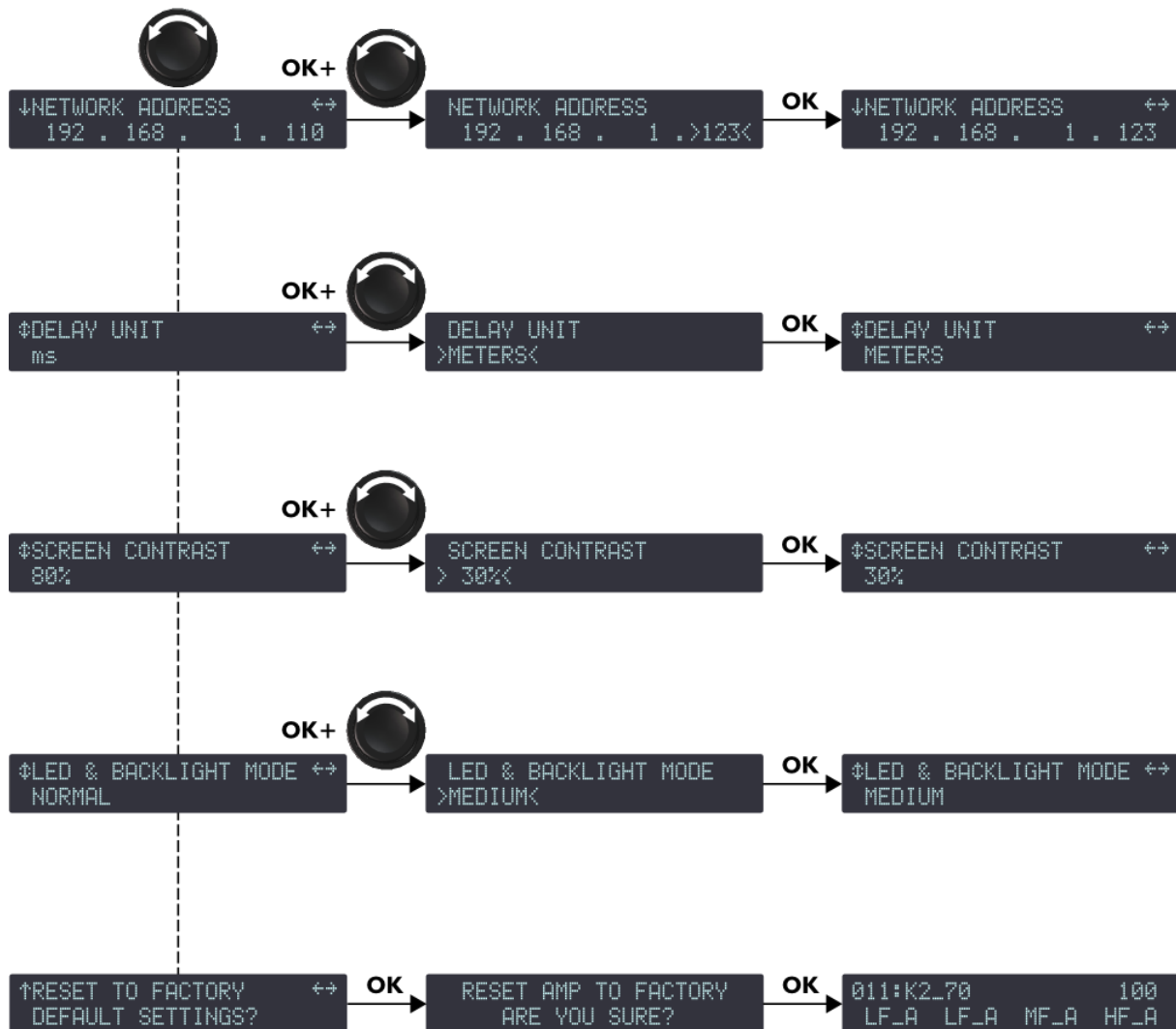

Figure 41: OPTIONS menu pages

4.11.1 NETWORK ADDRESS

Remote control of amplified controllers requires setting up a private local area Ethernet network to interconnect up to 253 units with a single control computer (and possible additional devices such as Ethernet switches). It is called L-NET and uses a proprietary communication protocol based on TCP/IPv4 called L-COM. The IP addresses on the units are class C addresses and must be set manually. The default subnet for L-NET is **192.168.1.0**.



IP address setting

Each unit must be given an IP address that is not already in use by another device on the network. For practical reasons, it is suggested to start numbering the units at **192.168.1.1** and then **192.168.1.2**, **192.168.1.3**, etc. and manually set the control computer on **192.168.1.254**.



An IP address is a unique identifier for a network device on a given IP network. In IPv4 networking, it is made of 4 bytes. In class C private local area IP subnets, the three first bytes are the network prefix and the last byte is the device identifier on the subnet. Regarding device identifiers, two numbers are reserved: **0** for designating the subnet, and **255** to communicate with all devices of the subnet (aka the IP broadcast address).

To select the IP address of a controller, follow these steps:

1. From the main menu select **OPTIONS** and press the **OK** key or the encoder wheel (or **ESC** to abort).
2. Press the **OK** key or the encoder wheel to enter the **NETWORK ADDRESS** page (or **ESC** to abort).
3. Turn the encoder wheel to select a value for the last byte.



Value setting resolution

- ▶ Turn the encoder wheel to obtain a 1-step resolution.
- ▶ Press and turn the encoder wheel to obtain a 10-step resolution.

4. Press the **OK** key to validate the setting (or **ESC** to abort).

For example, in Figure 41 the IP address has been modified from **192.168.1.110** to **192.168.1.123**.



Subnet modification

According to the network administration requirements the default subnet (**192.168.1.0**) can be modified entering new values for the three first bytes as follows:

1. Long-click on the key located just below the number to modify until it is selected.
2. Turn the encoder wheel to select a new value and press the **OK** key to validate.
3. Repeat the procedure for all numbers to modify.

LA4X Amplified Controller

user manual

version 8.0

4.11.2 DELAY UNIT

Delay values can be displayed in **ms** (milliseconds), **SAMPLES**, **METERS** or **FEET**. The values in meters or feet are given for a temperature of 20 °C.

To select the delay unit follow these steps:

1. From the main menu select **OPTIONS** and press the **OK** key or the encoder wheel (or **ESC** to abort).
2. Turn the encoder wheel to select **DELAY UNIT**.
3. Press the **OK** key or the encoder wheel to enter the page (or **ESC** to abort).
4. Turn the encoder wheel to select the chosen setting.
5. Press the **OK** key or the encoder wheel to validate the setting (or **ESC** to abort).

For example, in Figure 41 the delay unit has been modified from **ms** to **METERS**.

4.11.3 SCREEN CONTRAST

To set the LCD screen contrast follow these steps:

1. From the main menu select **OPTIONS** and press the **OK** key or the encoder wheel (or **ESC** to abort).
2. Turn the encoder wheel to select **SCREEN CONTRAST**.
3. Press the **OK** key or the encoder wheel to enter the page (or **ESC** to abort).
4. Turn the encoder wheel to select a value between **0** and **100 %**.
5. Press the **OK** key or the encoder wheel to validate the setting (or **ESC** to abort).

For example, in Figure 41 the screen contrast has been modified from **80 %** to **30 %**.

4.11.4 LED & BACKLIGHT MODE

The brightness of the LED and the LCD screen can be set to **OFF**, **LOW**, **MEDIUM**, **NORMAL** or **SUNLIGHT**.

To set the LED and LCD screen backlight mode follow these steps:

1. From the main menu select **OPTIONS** and press the **OK** key or the encoder wheel (or **ESC** to abort).
2. Turn the encoder wheel to select **LED & BACKLIGHT MODE**.
3. Press the **OK** key or the encoder wheel to enter the page (or **ESC** to abort).
4. Turn the encoder wheel to select the chosen setting.
5. Press the **OK** key or the encoder wheel to validate the setting (or **ESC** to abort).

For example, in Figure 41 the backlight mode has been modified from **NORMAL** to **MEDIUM**.



4.11.5 RESET TO FACTORY DEFAULT SETTINGS?

To reset the amplified controller to its factory default settings follow these steps (see also Figure 41):

1. From the main menu select **OPTIONS** and press the **OK** key or the encoder wheel (or **ESC** to abort).
2. Turn the encoder wheel to select **RESET TO FACTORY DEFAULT SETTINGS?**
The controller displays **RESET AMP TO FACTORY, ARE YOU SURE?**
3. Press the **OK** key or the encoder wheel to confirm (or **ESC** to abort).
The start-up sequence is launched (refer to section 4.1). When complete, the main screen is displayed with the default preset memory (011), indicating that the amplified controller has returned to its factory default settings and that all user memories have been deleted.



Resetting to factory default settings includes loading the preset from memory 011.
The amplified controller retains its IP address.

LA4X Amplified Controller

user manual

version 8.0

APPENDIX A: PROTECTION SYSTEMS

The LA4X electronic vital parts are continuously monitored by the embedded operating system to optimize the power resources while ensuring safety even under extreme conditions. Each time a protection system is activated, a warning message blinks on screen and the **STATUS** LED is also lit in red.



Remote monitoring

In LA Network Manager the activation of a protection system is indicated by an event message (refer to the **LA Network Manager video tutorial**).

Output channel temperature

The fans associated to the heat sinks operate permanently, but as long as the temperature remains below 45 °C they run at their slowest speed. Above 45 °C the speed is increased until it reaches its maximum value.

If a temperature of more than **60 °C** is detected at output channel **x**, the signal delivered at this output channel is attenuated and the controller displays **High Temperature Chx**, see the figure on the right.

```
High Temperature Chx
Channel Attenuated
```

If the temperature exceeds **65 °C**, channel **x** is muted and the controller displays **Over Temperature Chx**, see the figure on the right.

In both cases the protection will automatically be disengaged when the temperature returns to nominal state.

```
Over Temperature Chx
Channel Muted
```

If one of the two fans is ineffective, the controller displays **Fan blocked**, see the figure on the right.

The controller remains operational but there is a risk of temperature rising.

```
System Message
Fan blocked
```

Output channel current

The output channels are continuously monitored for unexpected current values (error).

If an external error is detected at output channel **x** (typically due to a short-circuit in a cable) this channel is muted and the controller displays **Error on Channel x**, see the figure on the right.

The channel will automatically be unmuted as soon as the issue is solved.

```
Error on Channel x
Channel Muted
```

If an internal error is detected at output channel **x** (typically due to a cross-conduct in the power stage) this channel is disabled and the controller displays **Error on Channel x**, see the figure on the right.

For safety reasons, the other channel in its pair (OUT 1/2 or OUT 3/4) is also disabled.

The controller must be sent to an L-Acoustics® representative for maintenance.

```
Error on Channel x
Channel Disabled
```

Speakers

The L-DRIVE transducer protection system provides a dual analysis of both signal intensity and voltage in real time and RMS. Under extreme conditions, when component membranes reach the over-exursion zone or if the coil ensemble temperature reaches a critical point, L-DRIVE is activated and acts as a power regulator.

As a result, the amount of power delivered at any channel is adjusted to the dynamic and thermal capacity of each individual transducer.



Other system messages

If the amplified controller detects a connection attempt from a version of **LA Network Manager** that is not compatible with the unit firmware (typically because the version of **LA Network Manager** is too old to manage the latest firmware features), the amplified controller displays **Invalid L-NET client**.

A screenshot of a system message displayed on a dark background. The text is white and reads: "System message" followed by "Invalid L-NET client" on the next line.

```
System message
Invalid L-NET client
```

Update **LA Network Manager** to version 2.3.0.0 minimum.

LA4X Amplified Controller user manual

version 8.0

APPENDIX B: APPROVALS

EC declaration of conformity

L-Acoustics

13 rue Levacher Cintrat
Parc de la Fontaine de Jouvence
91462 Marcoussis Cedex
France

states that the LA4X is in conformity with the provisions of:

2014/35/EU: Low Voltage Directive
2004/108/EC: Electro-Magnetic Compatibility Directive

Applied standards:

EN 60065:2002+A1:2006+A11:2008+A2:2010+A12:2011 Safety requirements for audio, video and similar electronic apparatus
EN55103-1: 2009+A1:2012 Electromagnetic compatibility - Product family standard for audio, video, audio-visual and entertainment lighting control apparatus for professional use - Part 1: Emissions
EN55103-2: 2009 Electromagnetic compatibility - Product family standard for audio, video, audio-visual and entertainment lighting control apparatus for professional use - Part 2: Immunity

CE marking date: 2013

Issued in Marcoussis, France

16/07/2013



Genio KRONAUER, Electronics Director

Additional approvals

The LA4X amplified controller holds the following certificates:

KC, PSE, CSA and CCC





APPENDIX C: SPECIFICATIONS

GENERAL

Output power EIA (1% THD, 1 kHz, all channels driven)	4 x 1000 W RMS (at 4 or 8 Ω)						
Max output voltage	150 V (Peak voltage, no load)						
Amplification class	Class D						
Digital Signal Processor (DSP)	SHARC 32 bit, floating point, 96 kHz sampling rate						
Frequency response	20 Hz-20 kHz (±0.25 dB at 8 Ω)						
Distortion THD+N	< 0.05 % (20 Hz-10 kHz, 8 Ω, 11 dB below rated power)						
Output dynamic range	110 dB (20 Hz-20 kHz, 8 Ω, A-weighted)						
Amplification gain	32 dB						
Noise level	-71 dBV (20 Hz-20 kHz, 8 Ω, A-weighted)						
Channel separation	> 80 dB (at 1 kHz, 8 Ω)						
Damping factor	> 500 (100 Hz and below, 8 Ω)						
Mains input power and current draw (all channels driven)	Maximum output power			Mains input power and current draw			
	Load	Nb. of driven channels	Power per channel	1/3 Output Power (-5 dB)	1/8 Output Power (-9 dB)	IDLE	Standby
	4 or 8 Ω	4	1000 W	7 A / 1600 W	3 A / 750 W	0.26A / 60 W	< 0.1 A / 11 W
Current values given for a mains rated at 230 V. Multiply by 2.3 for 100 V, 1.9 for 120 V or 1.15 for 200 V.							
Power supply	Model	universal SMPS (Switched Mode Power Supply)					
	Power Factor Correction (PFC)	yes					
	Mains ratings	cos φ > 0.9 (4 Ω, full power) 100-240 V ~ ±10 %, 50-60 Hz					
	Operating temperature	Room temperature	from 0 °C to +50 °C				
Circuits protection	heat-sinks temperature monitoring						
	output over current protection						
Transducers protection	L-DRIVE thermal and over excursion protection						
Fans	2 fans, temperature-controlled speed						
Fans noise (free field, 1 m)	At minimum speed	20 dBA					
	At maximum speed	45 dBA					
Indicators	POWER LED						
	4 mute LED						
	STATUS LED						
	L-NET presence LED						
Output Connectors	For each output: LOAD, signal, and LIMIT/CLIP level LED						
	4 x 4-point SpeakON	OUT1 to OUT4 (including OUT1/2 and OUT3/4)					
L-NET connectors	2 x Fast Ethernet EtherCON						

LA4X Amplified Controller

user manual

version 8.0

INPUT SIGNAL DISTRIBUTION

Connectors	Input	4 Neutrik® female XLR3, IEC 268, ESD protected
	Link	4 Neutrik® male XLR3, IEC 268, ESD protected
Available input connectors vs. input mode	Analog AB / Analog CD	IN A, IN B / IN C, IN D (4 connectors, 4 channels)
	Analog AB / Digital CD	IN A, IN B / IN C&D (3 connectors, 4 channels)
	Digital AB / Analog CD	IN A&B / IN C, IN D (3 connectors, 4 channels)
	Digital AB / Digital CD	IN A&B / IN C&D (2 connectors, 4 channels)
Link connectors	Analog input mode	passively connected
	Digital input mode	electronically buffered, failsafe relay

ANALOG INPUT DATA

Input impedance	22 kΩ (balanced)
Max input level	22 dBu (balanced, THD 1 %)
Latency	3.84 ms
	0.76 ms with low latency presets
A/D conversion	four cascaded 24-bit analog/digital converters (128 dB dynamic range)

DIGITAL INPUT DATA

Supported input formats	Standard	AES/EBU (AES3) or electrical S/PDIF (IEC 60958 Type II)
	Sampling frequency (Fs)	44.1, 48, 64, 88.2, 96, 128, 176.4, or 192 kHz
	Word length	16, 18, 20 or 24 bits
Input gain	Adjustable from -12 dB to +12 dB by 0.1 dB steps	
Latency	3.84 ms (independent of the input sampling frequency)	
	0.76 ms with low latency presets (independent of the input sampling frequency)	
Sample Rate Converter (SRC)	Sampling frequency	96 kHz (SRC referenced to the controller internal clock)
	Word length	24 bits
	Dynamic range	140 dB
	Distortion (THD+N)	< -120 dBfs
	Bandpass ripple	±0.05 dB (20 Hz-40 kHz, 96 kHz)
Automatic fallback option	Mode	AB to CD
	Switchover conditions	digital to analog or digital to digital no clock, loss of lock, CRC error, bipolar encoding error or data slip
	Constant delay	yes (independent of input Fs)
	Constant level	yes (upon user setting of AES/EBU in gain, independent of input Fs)
	Revert to AES/EBU	manual user selection

Neutrik, etherCON and speakON are registered trademarks of Neutrik AG

PHYSICAL DATA

Dimensions

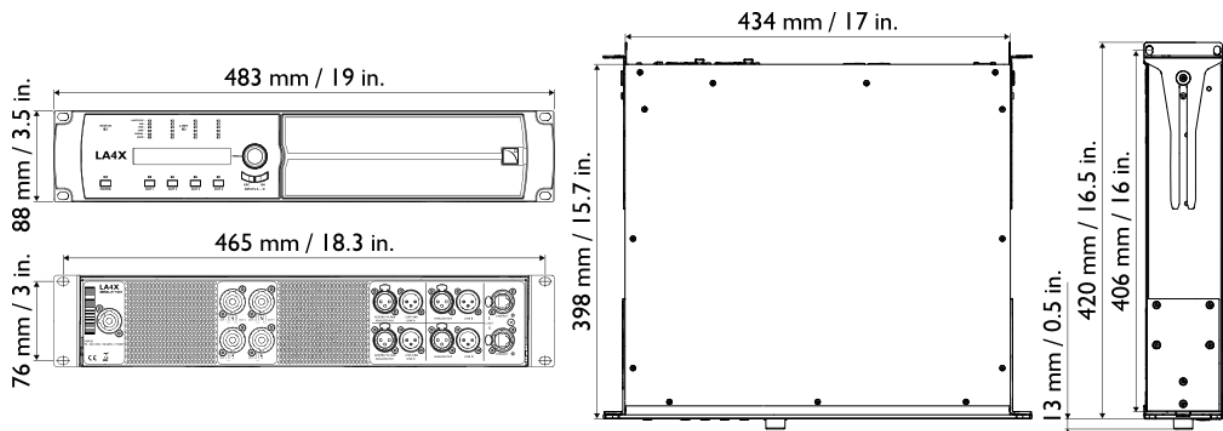

Weight	11.3 kg / 24.9 lb
Finish	black
Protection rating	IP3x



Document reference: LA4X_UM_EN Version: 8.0

Distribution date: April 4, 2016

© 2016 L-Acoustics®. All rights reserved.

**No part of this publication may be reproduced or transmitted in any form
or by any means without the express written consent of the publisher.**